



## Narol Textile Infrastructure & Enviro Management - CETP

ATPA Earth, RS no 170 Part, Opp Balaji Petrol Pump.  
Piplaj Pirana Road, Piplaj, Narol Ahmedabad 382405  
Tel: +91-079-29708230

Email: [jkvceo@ntiem.com](mailto:jkvceo@ntiem.com) Website: [ntiem.com](http://ntiem.com)

### RE-TENDER NOTICE

#### RE-TENDER NOTICE – DESIGN, SUPPLY, CONSTRUCT, ERECT, INSTALL AND TRIAL RUN OF MAIN AIR GRID PIPING SYSTEM FOR AIR DISTRIBUTION ON TURNKEY BASIS FOR TEXTILE PROCESSING WASTE WATER TREATMENT CETP PLANT

Tender No: NTIEM/130MLD/Dec/004-2023

Date: 01-12-2023

**NAROL TEXTILES INFRASTRUCTURE & ENVIRO MANAGEMENT INVITES SEALED BIDS FROM A REPUTED SUPPLIER / MANUFACTURERS / CONTRACTORS FOR DESIGN, SUPPLY, CONSTRUCT, ERECT, INSTALL AND TRIAL RUN OF MAIN AIR GRID PIPING SYSTEM FOR AIR DISTRIBUTION ON TURNKEY BASIS UNDER CAPACITY UPGRADATION PROJECT FROM 100 MLD TO 130 MLD FACILITY FOR TEXTILE CETP AT GYASPUR, AHMEDABAD.**

- The tender notice along with detailed terms and conditions is available on the official website [www.ntiem.com/tender](http://www.ntiem.com/tender) from 20 May 2024 to 05 June 2024 up to 16.00pm which may be downloaded free of cost.
- Interested bidder's full-filling Eligibility Criteria are requested to download the tender document & submit it on or before 05 June 2024, up to 17.00 PM at the above address.





# Narol Textile Infrastructure & Enviro Management - CETP

ATPA Earth, RS no 170 Part, Opp Balaji Petrol Pump.  
 Piplaj Pirana Road, Piplaj, Narol Ahmedabad 382405  
 Email: [jkvceo@ntiem.com](mailto:jkvceo@ntiem.com) ; [vipulmanager@ntiem.com](mailto:vipulmanager@ntiem.com)

Tender Document Ref: NTIEM/130 MLD/Dec/004-2023  
 Date:01-12-2023

## RE-TENDER NOTICE – DESIGN, SUPPLY, CONSTRUCT, ERECT, INSTALL AND TRIAL RUN OF MAIN AIR GRID PIPING SYSTEM FOR AIR DISTRIBUTION ON TURNKEY BASIS FOR TEXTILE PROCESSING WASTE WATER TREATMENT CETP PLANT

CEO, Narol Textiles Infrastructure & Enviro Management invites sealed bids from a reputed Manufacturer / Suppliers / Contractors Design, Supply, Construct, Erect, Install And Trial Run Of Main Air Grid Piping System For Air Distribution On Turnkey Basis Under capacity Upgradation Project from 100 MLD to 130 MLD facility for textile CETP at Gyaspur, Ahmedabad.

The tender notice along with detailed terms and conditions is available on the official website [www.ntiem.com/tender](http://www.ntiem.com/tender) which may be downloaded free of cost for use by interested bidders.

The Tender are required to submit duly filled with Techno Commercial offer, required documents and attested Xerox copies of registration of Firm/Agencies/individuals, PAN, PF, Income-tax Clearance of Last 3 Years, GST Certificate, Turnover Certificate, Experience Certificate, etc. & Earnest Money Deposit (EMD) by way of Demand Draft Drawn in the name of Narol Textile Infrastructure & Enviro Management Payable at Ahmedabad.

Tender Document Download Start Date	20-05-2024 from Morning 11:00 AM
Tender Document Download End Date	05-06-2024 at 16:00 PM
Pre Bid Meeting	31-05-2023 at 15:00 pm
Last Date and time for Physical Submission of Tender Document (Technical and Commercial Bid along With EMD and Tender Fees)	The physical documents should reach by hand delivery / Speed or Registered Post / Courier at our office address at Narol Textile Infrastructure & Enviro Management ATPA Earth, RS no 170 Part, Opp Balaji Petrol Pump.

	Piplaj Pirana Road, Piplaj, Narol Ahmedabad 382405 On or before 16:00 PM on Tender End Date
Bid / Tender Document Fees	Rs 15,000 + GST Rs 2700 = 17,700 (Rs Seventeen Thousand Seven Hundred Only) by way of Demand Draft issued by any Schedule Commercial Bank payable at Ahmedabad in favor of "Narol Textile Infrastructure & Enviro Management"
Earnest Money Deposit (EMD)	2 % by way of Demand Draft issued by any Schedule Commercial Bank payable at Ahmedabad in favor of "Narol Textile Infrastructure & Enviro Management"
Bid Opening Date	Technical Bid: 17:00 PM on Tender End Date Commercial Bid: Inform Later On

The Tenders/Quotation received late or without all documents, EMD, and Tender fees will be rejected summarily.

CEO, Narol Textiles Infrastructure & Enviro Management reserves the right to reject or cancel any or all quotations without assigning any reasons.

By Order of

CEO,

Narol Textiles Infrastructure & Enviro Management



## Narol Textile Infrastructure & Enviro Management

This is Re-Tender document for bidding.

TENDER DOCUMENT – DESIGN, SUPPLY, CONSTRUCT,  
ERECT, INSTALL AND TRIAL RUN OF MAIN AIR GRID  
PIPING SYSTEM FOR AIR DISTRIBUTION ON TURNKEY  
BASIS UNDER CAPACITY UPGRADATION PROJECT FROM  
100 MLD TO 130 MLD FACILITY FOR TEXTILE CETP AT  
GYASPUR, AHMEDABAD.

Prepared for: Narol Textile Infrastructure & Enviro Management.

Prepared by: Narol Textile Infrastructure & Enviro Management.

01 December 2023

Bid Inviting Officer

CEO

Narol Textile Infrastructure & Enviro Management

ATPA Earth, RS no 170 Part, Opp Balaji Petrol Pump.

Piplaj Pirana Road, Piplaj, Narol Ahmedabad 382405

Email: [jkvceo@ntiem.com](mailto:jkvceo@ntiem.com) ; [vipulmanager@ntiem.com](mailto:vipulmanager@ntiem.com)

Contact No: 9427958773 ; 9824754138

This document is an extended part of the Detail Project Report. A detailed Project Report (DPR) document has been developed under an agreement between Narol Textile Infrastructure & Enviro Management (NTIEM) based in Ahmedabad, Gujarat, India and (JMSI) based in West Palm Beach, Florida, USA towards the operation and modification/upgrade of the 100 MLD to 130 MLD Common Effluent Treatment Plant (CETP) at Gyaspur, Ahmedabad, Gujarat, India.

This document is the property of NTIEM. No part of this document, including all original concepts and ideas contained herein, both technical and commercial, may be reproduced or transmitted in any form, or by any means, electronic or mechanical, for any purpose without the express written permission of JMSI. NTIEM shall utilize the technical and commercial content of the document within the agreement made with JMSI and for implementation of the operation and upgrade of the project.

## NOTICE INVITING TENDER

CEO, Narol Textiles Infrastructure & Enviro Management invites sealed bids from a reputed Manufacturer / Suppliers / Contractors for Design, Supply, Construct, Erect, Install And Trial Run Of Main Air Grid Piping System For Air Distribution On Turnkey Basis Under capacity Upgradation Project from 100 MLD to 130 MLD facility for textile CETP at Gyaspur, Ahmedabad.

The Manufacturer shall be well equipped to manage such large size projects and should meet the eligibility criteria specified in the tender document. The Manufacturer shall have enough experience in providing such product for established, up gradation/expansion of industrial Effluent treatment plant.

### Brief Information on Tender

Officer Inviting Bid and Bid Opening Authority	CEO Narol Textile Infrastructure & Enviro Management ATPA Earth, RS no 170 Part, Opp Balaji Petrol Pump. Piplaj Pirana Road, Piplaj, Narol Ahmedabad 382405
Name of Project	Capacity Upgradation of CETP from 100 MLD to 130 MLD
Nature of Work	Design, Supply, Construct, Erect, Install And Trial Run Of Main Air Grid Piping System For Air Distribution ON TURNKEY BASIS Under capacity Upgradation Project from 100 MLD to 130 MLD facility for textile CETP at Gyaspur, Ahmedabad.
Tender Document (Bid) Reference No	NTIEM/130MLD/Dec/004-2023
Execution Time Frame (Contract / Agreement Period)	03 months from the date of award of tender and signing the contract / agreement and deposition of Security Deposit. And / or till completion of the Job whichever is earlier.
Class of Bidder	Reputed Manufacturer / Suppliers / Contractors registered with Government of India, Government of Gujarat, Municipalities, Semi Government and Large size Private Organizations with a good track record of executing such or large size of work.
Tender Currency	INR
Bid / Tender Document Fees	Rs 15,000 + GST Rs 2700 = 17,700 (Rs Seventeen Thousand Seven Hundred Only) by way of Demand Draft issued by any Schedule Commercial Bank payable at Ahmedabad in favor of "Narol Textile Infrastructure & Enviro Management"
Earnest Money Deposit (EMD)	2 % of the bid amount by way of Demand Draft issued by any Schedule Commercial Bank payable

	at Ahmedabad in favor of "Narol Textile Infrastructure & Enviro Management"
Tender Document Download Start Date (Tender Start Date)	20-05-2024 from Morning 11:00 AM
Tender Document Download End Date (Tender End Date)	05-06-2024 at 16:00 PM
Pre-Bid Meeting	31-05-2024 at 15:00 pm
Last Date and time for Physical Submission of Tender Document (Technical and Commercial Bid along With EMD and Tender Fees)	The physical documents should reach by hand delivery / Speed or Registered Post / Courier at our office address at Narol Textile Infrastructure & Enviro Management ATPA Earth, RS no 170 Part, Opp Balaji Petrol Pump. Piplaj Pirana Road, Piplaj, Narol Ahmedabad 382405 On or before 16:00 PM on Tender End Date
Bid Opening Date	Technical Bid on Tender End Date at 17:00 PM Commercial Bid: Inform Later On
Bid Validity Period	180 Days from the date of Opening of the Commercial Bid
Security Deposit (By Successful Bidder only)	3 % of the bid Amount by way of Bank Guarantee / Demand Draft Issued by any Schedule Commercial Bank payable at Ahmedabad in favor of "Narol Textile Infrastructure & Enviro Management"  The 2 % EMD of Successful bidder will be converted to security deposit. In any case, the security deposit shall not exceed 5 %

## General Terms and Condition of Bidding

1. The bid document can be downloaded from the website [www.ntiem.com/tender](http://www.ntiem.com/tender)
2. The cost of the Tender document will not be refunded under any circumstances.
3. EMD in the form specified in the Tender document only shall be accepted.
4. Technical and Commercial bids have to be submitted in two separate seal covers in hard copy at NTIEM office.
5. All pages of the bid documents need to be signed and stamped
6. Incomplete offers / bids shall be rejected without any notice
7. Conditional tender shall not be accepted.
8. The Successful bidder shall enter into an Agreement with the Narol Textile Infrastructure & Enviro Management on Rs. 300/- Stamp Paper.
9. CEO, Narol Textile Infrastructure & Enviro Management (NTIEM) reserves the right to accept or reject any or all tenders without assigning any reason thereof. This Tender notice and Tender Document shall form a part of the Contract / Agreement document.
10. The tenderers are advised to read carefully the "Instruction" and "Eligibility Criteria" contained in the tender documents.
11. Work offered should be strictly as per specifications mentioned in this tender document.
12. Once quoted, the Bidder shall not make any subsequent price changes, whether resulting or arising out of any technical/commercial clarifications sought regarding the bid, even if any deviation or exclusion may be specifically stated in the bid. Such price changes shall render the bid liable for rejection.
13. The Tender, as stated hereunder, and containing all two envelopes having Pre-Qualification, Technical Bid and the Price Bid Documents duly filled in should be sent so as to reach the CEO, Narol Textile Infrastructure & Enviro Management, ATPA Earth, RS no 170 Part, Opp Balaji Petrol Pump. Piplaj Pirana Road, Piplaj, Narol Ahmedabad 382405 on or before 16:00 Hrs. On tender end date
14. The Envelope No. 1
  - a. i.e., the first envelope shall contain Pre-Qualification Document and Technical Bid shall be marked as Envelope No.1.
15. Envelope No. 2
  - a. i.e., the second envelope shall contain the Price Bid Document.
16. All the Envelopes shall be Sealed Separately and the two sealed envelopes No. 1 and 2 shall be placed in one main cover which should thereafter be also sealed and super scribed as "TENDER For Design, Supply, Construct, Erect, Install And Trial Run Of Main Air Grid Piping System For Air Distribution ON TURNKEY BASIS under Textile Effluent CETP Capacity

Upgradation From 100 MLD To 130 MLD Project At Gyaspur, Ahmedabad". While opening the initial bids, the main sealed cover and cover containing Envelope No.1 only shall be opened. The bidders meeting the qualification criteria and requirements as per tender conditions only shall be consider pre-qualified bidders only before opening the price bid. Envelope 2 containing Price Bid. The document will thereafter be opened in respect of those agencies who are pre-qualified. The second envelope containing the price bid document will be opened for only pre-qualified bidders only.

The following details shall be submitted in hard copy at the prescribed address:

17. Envelop No. 1:

- a. Tender fees in prescribed format.
- b. Earnest Money Deposit in prescribed format.
- c. Technical bid documents along with all necessary supporting documents in hard copy as per mentioned in Check list for documents to be submit.

18. Envelop No. 2:

- a. a. Price Bid

19. Tender Validity Period:

- a. The validity period of the tender submitted for this work shall be of One Hundred Eighty (180) calendar days from the last date of submission of tender documents and the Tenderer shall not be allowed to withdraw or modify the tender offer on his own during the validity period.

20. Rights Reserved:

- a. Without assigning any reason, CEO, Narol Textile Infrastructure & Enviro Management reserves the right to reject the lowest or any other or all tenders or part of its. To waive any informality or irregularity in any tender, which in the opinion of the CEO does not appear to be in its best interest and the tenderer shall have no cause of action or claim against Narol Textile Infrastructure & Enviro Management. or its officers, employee, successors or assignees for rejection of this tender.
- b. CEO further reserves the right to withhold issuance of the notice to proceed, after execution of the Contract / Agreement by the successful Tenderer. CEO is not obliged to give reasons for any such action.

21. This notice of inviting tenders shall form part of the Contract / Agreement documents.

22. Only a successful bidder / tenderer shall have to submit the information required for bank account through Electronic Credit System (ECS).

23. The Manufacturer / Supplier / Contractor shall submit the tender, who satisfies each and every condition laid down in this notice and tender documents, failing which; the tender will be liable for rejection.

24. Liquidated damages: liquidated damages shall be levied @ 0.75 % of the basic value of material to supply by Manufacturer / Supplier / Contractor per week up to 100 % of the Total Accepted Tender Value for the delay in required submissions from the successful bidder / tenderer. However, the Authority will decide final verdict based on facts and reasons produced along with supporting before him.



25. The successful Bidder / tenderer shall have to submit an undertaking letter that they are not debarred (Even in past) by any Government/Non-Government/Semi-Government Agency /Agencies / Municipalities / Private sector Enterprises.
26. Eventhough the bidder meet the qualifying criteria, they are subject to be disqualified if they have
- Made misleading or false representation in the form, statements submitted and /or
  - Records of Poor Performance such as abandoning the works, rescinding of contract for which the reasons are attributable to the non-performance of the contractor, consistent history of litigation awarded against the bidder or financial failure due to bankruptcy, etc. and /or participated in the previous bidding for the same work and that quotes unreasonably high/low bids prices and could not furnish rational justification to the employer.
27. Any discrepancy and misinterpretation between BOQ (Price bid) and Scope of Work shall not be allowed and shall be item wise consistent for a smooth process. Any quote/tender in contradiction to the scope of work shall be straightaway rejected.
28. Tenure of Work
- Tenure for the work: It shall be as per mentioned in Brief Information on Tender under Tender Notice from the date of signing the agreement and deposition of Security Deposit.
29. Agreement: Successful Bidder / tenderer will have to execute the agreement with CEO NaroI Textile Infrastructure & Enviro Management. as per prevailing rules, terms, conditions, etc. on Rs.300/- Stamp Paper.
30. Milestones
- a. Schedules of submissions are as under:

Schedules	Time Frame to perform activities by the consultant mentioned in schedules
Submission of Design data, Civil Structure & Foundation details, Drawings, SLDs, BOQ with preferred make, List of activity at site, Schedules of activity with timeline and other activity as per the scope and applicability of successful bidders	Within 4 Week from the date of award of tender letter and submission of Security Deposit
Self-certified intimation regarding start of manufacturing / Sourcing / Constructing.	With in 5 days from the approval from the Authority
Photographs and self-certified progress report	On the 30 <sup>th</sup> day from the previous submissions. (This has to share on monthly basis)
Verification of all required arrangements made at site which are outside scope of successful bidders, for Design, Supply, Construct, Erect, Install And Trial Run Of Main Air Grid Piping System For Air Distribution On Turnkey Basis.	Up on receiving confirmation from NTIEM side with in 1 Week.
Supply of Material to Site after inspection.	As per submission made in technical bid.

## 31. Schedules of Payments Terms

a. Schedules of Payments are as under:

Sr. No.	Schedules	Payment
1	Total 20 % advance to be released with PO after submission of Security Deposit of 3 %	70.0 % value as per Sr No 1 of Price Bid
2	Total 70 % to be released upon successful dispatch of all the agreed supplies at site on stage wise prorata basis	70.0 % value as per Sr No 1 of Price Bid
3	Balance 10 % of amount to be paid on successful and satisfactory completion of 6 months of operations at site (complying with all respective operational performance guarantees)	10.0 % value as per Sr No 1 of Price Bid
	Total	100.0%

Notes: The above amount are total approved consideration with GST. However, rest all other taxes shall be included in consideration amount, Necessary TDS will be deducted from the bill amount as per prevailing notifications. (These considerations are inclusive of all other direct and indirect taxes and GST). All the payment from NTIEM side will be made either by Letter of Credit or by Bank Transfer.

32. Sole Arbitrator: Arbitration: Any dispute or claim arising out of or in connection with this Contract / Agreement, including any question regarding its existence, validity or termination, shall be referred to and finally resolved by arbitration as per the Indian Arbitration and Conciliation Act, 1996, as amended from time to time. The seat and venue of arbitration shall be Ahmedabad, India, and the language of the arbitration shall be English. The arbitration tribunal shall consist of a single arbitrator to be appointed by mutual agreement of the parties, or failing such agreement, as per applicable provisions of Indian Arbitration Act, 1996 and amendments thereto. The decision of the arbitrator shall be final and binding on the parties and may be enforced in any court of competent jurisdiction.

33. Exclusive Jurisdiction: Any dispute arising out of or in connection with this Contract / Agreement shall be subject to the exclusive jurisdiction of the courts in Ahmedabad, India

## INSTRUCTION FOR BIDDERS

### ARTICLE-1: DEFINITIONS

- In this document, unless the context specifies otherwise, the following words and phrases shall mean and include:
  - “Agreement” means the document signed by the Authority and the successful bidder that incorporates any final corrections or modifications to the tender and is the legal document binding both the parties to all terms and conditions for the award of the Contract / Agreement.
  - “Authority” shall mean the CEO, Narol Textile Infrastructure & Enviro Management and/or its nominated officer and/or Project Implementation Committee.
  - “Bid” means the complete bidding document submitted by the bidders to the Authority and shall include any corrections, addenda and modifications made therein.
  - “Bidder” shall mean any firm in the form of Company, Partnership, Proprietor, eligible to participate in the tendering process and shall include the successful bidder during the currency of the Contract / Agreement.
  - “Contract period / Agreement Period” shall mean entire term of the Contract / Agreement as indicated in this tender document.
  - “Contract / Agreement” shall cover the whole terms & conditions of this Bid documents within time limits specified for which the Bidder shall be paid in accordance with the terms and conditions, terms of reference of the Agreement.
  - “Corrupt Practice” means the offering, giving, receiving or soliciting of anything of value, pressurizing to influence the action of a public official in the process of bidder selection and Contract / Agreement execution.
  - “Government” shall mean the Government of Gujarat and / or Government of India.
  - “Total Accepted Tender Value” means the total value of services / Supply as approved to be provided by the successful bidder.
  - “Month” means calendar month is one of the twelve months of the year. A period from a specified day in one month to the day numerically corresponding to that day in the following month, less one.
  - “Technically Eligible Bidder” means bidder fulfilling eligibility criteria as per tender document.
  - “Shortlisted Bidder” means a technically eligible bidder

### ARTICLE – 2: MANDATORY ELIGIBILITY CRITERIA FOR BIDDERS

- The bidder should be fulfilling the following conditions and must also submit documentary evidence in support of the fulfillment of these conditions while submitting the technical bid. Bids from consortiums are not allowed. Bids without documentary evidence will not be considered for further evaluation. Manufacturer / Supplier / Contractor should also satisfy the eligibility criteria as mentioned RFQ document - part of tender document apart from below mentioned.

Sr No	Eligibility Criteria	Supporting to Eligibility
1	Valid Registration / Empanelment Certificate with any Government / Semi Government Enterprise, Municipalities, Large size reputed private enterprise.	Copy of Registration if any.
2	The Bidders who are not registered with above agencies mentioned in point no 1 but has successfully executed similar or large capacity project can also bid.	PO/WO, Completion certificate of work not older than 2 years.
3	Valid PAN and GST Certificate	Provide Self Certified Copy of Registration with Number
4	The Bidder must have at satisfactory experience in Design, Supply, Construct, Erect, Install And Trial Run Of Main Air Grid Piping System For Air Distribution On Turnkey Basis of Such Capacity or larger than this for Waste Water Treatment - Infrastructure projects work.	Work order and completion certificate with in the last three financial years. Please Provide PO and Completion Certificate for minimum 5 Executed Orders. Out of these, One project should be of such large capacity or higher capacity than this.
5	The bidder should have positive Net worth of last year ending on 31st March 2023.  Minimum Network of Rs 1.00 Crs as per last audited Balance Sheet	The bidder shall submit CA certified audited Balance sheet and Income statement duly signed by the CA and authorized signatory/ies of the bidders  CA Certified Network Certificate.
6	Financial Criteria  Working Capital in excess of 1.0 Crs.  Profit after Tax Should be Positive for last year	Provide CA Certified Copy
7	The Bidder should have qualified & experienced manpower on his payroll. They should have their own/ Designing and manufacturing Facility with qualified team and infrastructure.	Self-certified letter of the list of manpower clearly showing their name, Age, basic qualification, and Experience. Should also share the details regarding their manufacturing facility infrastructure and Designing Facility infrastructure details.
8	The supplier must demonstrate the ability to offer onsite aftersales support in Gujarat, India, including sufficient spares stock facility in the region.	Self-certified letter along details of qualified service team should be attached with offer. Have to provide minimum turnaround time for any service request in self-certified letter.

Note: - Authority reserves the right to verify the claims made by the Bidders and to carry out the capability assessment of the Bidders and the decision of Authority shall be final in this regard.

## GENERAL TERMS AND CONDITIONS OF TENDER

### ARTICLE - 1: CHECKLIST OF DOCUMENTS COMPRISING THE BID

- The bid submitted shall have the following documents:
  - Part-I (Physical submission) EMD and Tender Fees / Bid Document Fee in the form prescribed in the Tender.
  - Part – II (Documents to be submitted for Technical Bid)
    - Bid duly signed & sealed (with official seal) in original on all pages with all pages duly numbered.
    - Registration Details: In case a bidder is a Company- Certified copy of Certificate of Incorporation for companies & Memorandum and Articles of Associations, Or In case of Proprietary Firm- Shop & Establishment certificate Or In case of Partnership Firm- Certified copy of the Registered Partnership deed Certified copies of documents submitted, as above, must be signed and carry the seal of the authorized signatory.
    - List of present Directors/ owners/ executive council members/ trustees/ Board members as applicable with a Correspondence address, telephone number, Fax number, email, and related details of the bidder.
    - Bidder should not be blacklisted/ banned/ disqualified/ declared ineligible / declared having a dissatisfactory performance by any government /quasi-government authority in India for the Design / supply of materials/ Installation, Erection and Commissioning / Under supply of Non-Standard or poor-quality product / carrying out operations and maintenance work / Repair and Retrofit jobs. Undertaking to be submitted as per attached format.
    - A copy of valid GST Registration.
    - Legal status (Individual, Proprietary firm, Partnership firm, Limited Company or Corporation) of the company along with statutory details (PAN No., GST Registration, Shop Establishment, and other required valid licenses).
    - General power of attorney/ Board of Directors resolution/ Deed of Authority Contract / Agreement and all correspondences/ documents thereof.
    - Income Tax Returns for the last three years along CA certified Balance sheet and Income statement duly signed by the statutory auditors and authorized signatory/ies of the Bidder for the Financial years 2020-21, 2021-22 & 2022-23.
    - Clause by clause compliance statement for the whole Tender Document including all Annexures.
    - Documents required as per Eligibility Criteria Article 1 Part II above duly signed by the authorized representatives of the bidder.
  - Part-III
    - Price Bid as per Annexure – 1 to be submitted in physical No deviations and/ or noncompliance clauses shall be allowed in the Financial Bid.

### ARTICLE – 2: BIDDING DOCUMENT

- Bidder is expected to examine all instructions, forms, terms and specifications in bidding documents. Failure to furnish all information required by bidding documents or submitting

a bid not substantially responsive to the bidding documents in every respect may result in the rejection of the Bid.

#### ARTICLE – 3: CLARIFICATION ON BIDDING DOCUMENTS

- Bidders can seek written clarifications before the date of the pre-bid meeting of the tender, to the email address: [jkvceo@ntiem.com](mailto:jkvceo@ntiem.com) The clarification shall be issued by the Authority during the pre-bid meeting and/or will be published on the website [www.ntiem.com](http://www.ntiem.com) The prospective bidder or its official representative/s [maximum 2 persons] is/are invited to attend the pre-bid meeting. The queries should necessarily be submitted clearly showing Document Reference (Section & Page Number), Content on which requires clarification, Points of Clarification

Note: Any query of the bidders/ Any agencies will not be entertained after the Pre-Bid meeting.

#### ARTICLE – 4: AMENDMENT OF BIDDING DOCUMENTS

- At any time prior to the deadline for submission of bids, the Authority for any reason, may modify the bidding documents by amendment.
- All prospective bidders may be notified of the amendment and such modifications will be binding on them. The same shall also be put up on the website [www.ntiem.com](http://www.ntiem.com)
- In order to allow prospective bidders a reasonable time to take the amendment into account in preparing their bids, Authority, at its own discretion, may extend the deadline for the submission of bids.

#### ARTICLE – 5: LANGUAGE OF BID

- The bid prepared by the bidder, as well as all correspondence and documents relating to the bid exchanged by the bidder and authority shall be in English. Supporting documents and printed literature furnished by the bidder may be in another language (Except in Hindi & Gujarati) provided they are accompanied by an accurate translation of the relevant pages in English. For purposes of interpretation of the bid, the translation shall govern.

#### ARTICLE – 6: COST OF BIDDING

- Bidder shall bear all costs associated with the preparation and submission of the bid and Authority will in no case be responsible for those costs, regardless of the conduct or outcome of the bidding process.

#### ARTICLE - 7: BID FORMS

- Wherever a specific form is prescribed in the tender document, the bidder shall use the form to provide relevant information. If the form does not provide space for any required information, space at the end of the form or additional sheets shall be used to convey the said information.
- For all other cases, the bidder shall design a form to hold the required information.
- Authority shall not be bound by any printed conditions or provisions in the bidder's bid forms.

#### ARTICLE - 8: FRAUDULENT & CORRUPT PRACTICE

- Fraudulent practice means a misrepresentation of facts in order to influence a procurement process or the execution of a Contract / Agreement and includes collusive practice among bidders (prior to or after Bid submission) designed to establish bid prices at artificial on competitive levels and to deprive the Authority of the benefits of free and open competition.
- Authority will reject a proposal for award if it determines that the bidder recommended for award has engaged in corrupt or fraudulent practices in competing for, or in executing, Contract / Agreement(s).

#### ARTICLE - 9: LACK OF INFORMATION TO BIDDER

- Bidder shall be deemed to have carefully examined all Contract / Agreement documents / this bid document to his entire satisfaction. Any lack of information shall not in any way relieve the Bidder of his responsibility to fulfill his obligation under the Contract / Agreement. Also, the bidder is required to make his own estimates regarding all costs associated with the Project. Authority shall not entertain any disputes in this regard after the bids have been submitted. Authority retains the right to ask for any missing information during the evaluation process.

#### ARTICLE - 10: CONTRACT / AGREEMENT OBLIGATIONS

- If after the award of the tender, the bidder does not sign the Contract / Agreement or fails to furnish the Security Deposit within the time limit prescribed by the Authority or fails to perform his obligations and work as per the specifications of this Contract / Agreement in a satisfactory manner, the Authority reserves the right to cancel the Contract / Agreement and apply all remedies available to him like forfeiture of EMD and Security Deposit and others under the terms and conditions of this document.

#### ARTICLE - 11: BID PRICE

- The Price bid should indicate the prices in the format / price schedule given in document. Bidder shall categorically confirm strict compliance with the following stipulation in respect of their offer.
  - Any effort by a Bidder or Bidder's agent/consultant or representative whatsoever described influencing the Authority in any way concerning scrutiny/ consideration/ evaluation/ comparison of the bid or decision concerning award of Contract / Agreement shall entail rejection of the bid.
  - Bidder should indicate a single consolidated rate for terms of Contract / Agreement / Supply based on the payment terms specified in the Tender.
  - Bids should be submitted directly by the bidder.
  - Price Bids of only qualified bidders as per eligibility criteria shall be opened.
  - Bidder quoting the lowest price shall be the preferred bidder for award. However, Authority reserves the absolute right to award the Contract / Agreement as per its requirements.
- Authority reserves the right to seek clarification/ justification from the Bidder on the bid price in case Authority deems it necessary. Based on the justification provided by the Bidder, if Authority feels that the price is unrealistic/ unfeasible in order to execute a project of this nature, Authority reserves the right to reject the said bid. The Bidders shall be governed by the decision of the Authority.

#### ARTICLE - 12: BID CURRENCY

- For the services required in the Tender, the prices shall be quoted in Indian Rupees. Payment for such services as shall be made in Indian Rupees only.

#### ARTICLE - 13: EARNEST MONEY DEPOSIT (EMD)

- The bidder shall furnish, as part of the Bid, EMD / Tender Security for the amount as stated in the Notice Inviting Tenders by DD in favor of "Narol Textile Infrastructure & Enviro Management" payable at Ahmedabad issued by any scheduled Commercial valid banks in India in a separate envelope. Only after the confirmation of valid EMD, the Technical Bid will be opened.
- No interest shall be paid on EMD.

- EMD of Bidders those who have not short-listed will be refunded within 30 days from the date of declaration of Short-listed Bidders.
- The EMD may be forfeited either in full or in part, at the discretion of Authority, on account of one or more of the following reasons:
  - Bidder withdraws its Bid during the period of Bid validity as stated in Article 14 below.
  - Bidder does not respond to requests for clarification of their Bid.
  - Bidder fails to co-operate in the Bid evaluation process, and
  - In case of a successful Bidder, the said Bidder fails:
    - 1) to sign the Agreement in time; and / or
    - 2) to furnish Security Deposit.

#### ARTICLE - 14: PERIOD OF VALIDITY OF BIDS

- Bids shall remain valid for 180 days after the date of Bid opening prescribed by the Authority. A Bid valid for a shorter period shall be rejected as non-responsive.
- In exceptional circumstances, the Authority may solicit Bidder's consent to an extension of the period of validity. The request and the responses thereto shall be made in writing. The EMD shall also be suitably extended. A Bidder granting the request is not required nor permitted to modify the Bid.

#### ARTICLE - 15: FORMAT AND SIGNING OF BID

- The original bid shall be typed or written in indelible ink and shall be signed by the Bidder or a person duly authorized to bind the Bidder to the Contract / Agreement. All pages of the bid shall be initialed by the person or persons signing the bid.
- The complete bid shall be without alteration or erasures, except those to accord with an instruction issued by the Authority or as necessary to correct errors made by the Bidder, in which case such corrections shall be initiated by the person or persons signing the bid.

#### ARTICLE - 16: SEALING AND MARKING OF BID

- Bidder shall submit their bids in two separate parts in sealed envelopes super-scribed with due date, time, project, and nature of bid (EMD, Bid).
- Part: I
  - Bid Document Fees / Tender Fee and EMD i.e. (EMD) in a separate sealed envelope super scribed with the tender reference number.
  - Self-certified list of documents to attach in technical bid.

NOTE: Filling up prices or price sensitive information in this part I, The authority will immediately disqualified the bidder.

- Part: II
  - Price Bid

NOTE: The envelopes containing Part-I and Part-II of the bid should be enclosed in a larger envelope duly sealed. The enclosed CUT-OUT Slips marked with tender details shall be filled and pasted on the envelopes. The outer envelope shall indicate the name and address of the Bidder to enable the bid to be returned unopened in cases it is declared 'late'.

- If the outer envelope is not sealed and marked as required, the Authority will assume no responsibility for the bid's misplacement or premature opening.



- If these envelopes are not sealed and marked as required, the Authority will assume no responsibility for the bid's misplacement or premature opening and rejection.

#### ARTICLE - 17: BID DUE DATE

- Bid must be received by the Authority at the address specified in the Tender Document not later than the time & date specified in the bid.
- Authority may, at its discretion, on giving reasonable notice by written communication to all prospective Bidders who have been issued the Tender documents, extend the bid due date, in which case all rights and obligations of the Authority and the Bidders, previously subject to the bid due date, shall thereafter be subject to the new bid due date as extended.

#### ARTICLE - 18: LATE BID / CONDITIONAL BID

- Any bid received by the Authority after the bid due date/ time prescribed in the Tender Document shall be rejected.
- Any bid indicating conditions beyond those indicated in this Tender Document i.e., conditional bid shall be rejected.

#### ARTICLE - 19: OPENING OF BIDS BY THE AUTHORITY

- Bids will be opened in the presence of Bidder's representatives, who choose to attend. The Bidder's representatives who are present shall sign a register evidencing their attendance.
- The Bidder's names, bid modifications or withdrawals, and the presence or absence of relevant EMD and such other details as the Authority at his/her discretion, may consider appropriate, will be announced at the opening.
- At the pre-decided time, the Authority contact person shall open the Technical Bids and list them for further evaluation. Any participating Bidder may depute a representative to witness these procedures.

#### ARTICLE - 20: CONTACTING THE AUTHORITY

- Bidder shall not approach the Authority officers outside of office hours and/ or outside the Authority premises, from the time of the Bid opening to the time the Contract / Agreement is awarded.
- Any effort by a Bidder to influence the Authority officers in the decisions on Bid evaluation bid comparison or Contract / Agreement award may result in rejection of the Bidder's offer. If the Bidder wishes to bring additional information to the notice of the Authority, it should do so in writing.

#### ARTICLE - 21: JOINT VENTURES / TRADER BIDDING

- The manufacturers / suppliers can bid jointly with their technical partner. In this case, the technical partner or Manufacturer / Supplier / Contractor has to undertake the warranty for performance and service support other than bidder. In this case both the parties have to sign a joint declaration for trader authorization letter which is attached herewith and is part of tender document.

#### ARTICLE - 22: BID EVALUATION

All evaluations will be carried out by the committee as detailed below:

- Preliminary Scrutiny will be based on compliance with all the terms and conditions of the Bid along with eligibility criteria. The Bidders who do not fulfill all the terms & condition and eligibility criteria shall be straight away rejected. All eligible Bids will be considered for further evaluation subject to compliance of the following:

- Bidders will have to submit the Bid Documents physically along with all the supporting documents.
- Bidders will have to submit a demand draft of EMD and tender fees physically. The decision of the Committee will be final in this regard.

#### Technical Evaluation

- The technical proposals will be opened on the mentioned date in this Bid Document. The Technical Bid will be examined by the committee formed for the purpose, on the basis of responsiveness to the scope of work and other details as mentioned herein the document.
- Technical Presentations: Authority will invite the eligible bidders for a detailed technical presentation on the proposal. Bidders will be informed at least 3 days prior to the scheduled presentation date (to be scheduled during the evaluation process of bids). The purpose of such presentations is to allow the bidders to present their proposed approach to the key points in their proposals.

- Financial Bid Opening

The financial bid of only the technically qualified Bidders shall be opened.

- Bid Evaluation Committee

The above evaluation shall be done by an Evaluation Committee decided by the Authority, The Committee shall determine the approach and methodologies for the issues, which may arise during the above-referred evaluation exercise and have not been addressed in this Tender Document. The decision of the Committee shall be final and binding on all the Bidders. After successful presentation, the bid evaluation committee can invite the revised price offers from all the technically qualified bidders. In this case, bidder must make the price better.

#### ARTICLE - 23: AUTHORITY'S RIGHT TO VARY SCOPE AT TIME OF AWARD

- If any change in the Scope of the Contract / Agreement causes an increase or decrease in the cost of, or the time required for, the Bidder's performance of any part of the work under the Contract / Agreement, an equitable adjustment shall be made in the Contract / Agreement Price or schedule of implementation, or both, and the Contract / Agreement, shall accordingly be amended. Any claims by the Bidder for adjustment under this Para must be asserted within ten (10) days from the date of the Bidder's receipt of the Authority changed order.

#### ARTICLE - 24: AUTHORITY'S RIGHT TO ACCEPT AND REJECT

- ANY/ ALL BIDS: Authority reserves the right to reject Any / All bid and annul the bidding process and reject all bids at any time prior to award of the Contract / Agreement without thereby incurring any liability to the affected Bidder(s) or any obligation to inform the affected Bidder(s) of the grounds for such decision.

#### ARTICLE - 25: NOTIFICATION OF AWARD & SIGNING OF CONTRACT / AGREEMENT

- Prior to the expiry of the period of Bid validity, the Authority will notify the successful Bidder in writing that its Bid has been accepted and send the successful Bidder the Contract / Agreement Form.
- Within 10 days of receipt of the Contract / Agreement Form, the successful Bidder shall sign and date the Contract / Agreement and return it to the Authority. If the successful Bidder thus selected fails to sign the Contract / Agreement and / or provides the Security Deposit as stipulated, the Authority reserves the right to offer the Tender - Contract / Agreement to the other Bidder and its EMD will be forfeited.

#### ARTICLE - 26: PERFORMANCE GUARANTEE

- The Contract / Agreement Security Deposit has to be submitted within TEN days of receipt of the Contract / Agreement/ Agreement/ Work Order / Purchase Order.
- If the successful Bidder fails to remit the Security Deposit within the time stated for the submission of the same by the Authority, the EMD remitted by him will be forfeited by the Authority and the bid will be held void.
- Upon the successful Bidder's furnishing of Security Deposit and signing of Contract / Agreement, the Authority will promptly notify all short-listed Bidders and will refund their EMD.
- The detailed performance criteria are provided in this tender document are to be filled based on design and to be prove at the site for the tenure of equipment life period with stated deviations. In case of failure in performance criteria mentioned by Manufacturer / Supplier / Contractor / Contractor, the authority will ask Manufacturer / Supplier / Contractor to take corrective action and to match the performance criteria.
- In case the Manufacturer / Supplier / Contractor fails in achieving the designed performance criteria, the balance payment is liable to forfeit. The Authority will take a final decision up on the damage due to non-performance of supplied product and take final call on liquidation damages.
- Authority will levy a liquidated damages in case the Bidder fails to provide the services specified by the Authority and/or specified in tender document in the Scope of Work and other conditions of this tender document. The amount of liquidated damages shall be commensurate with the nature of the breach/ defect/ deviation/ fault and as decided by Authority. Such an amount payable by the Bidder shall be final and binding and shall not exceed 100 % of the Total Accepted Tender Value of the bidder for the Contract / Agreement Period. On the Bidder repeatedly failing to rectify the faults / Providing the desired and committed performance criteria and achieving desired results within the time period as stated by the Authority, the Authority is free to cancel/terminate the Contract / Agreement by giving a one-month notice period. Also, the Authority may, at its discretion, get the deviations, and faults attended / rectified by any other Bidder / Agency at the risk and cost of the successful Bidder and the same will be recovered from the Bidder. It is specifically agreed that the stipulated liquidated damages mentioned in the clause is a genuine pre-estimate of damages which NTIEM would incur in case of breach by the bidder and NTIEM has an unconditional right to forfeit the security deposit and recover the balance liquidated damages. All disputes shall be subject to Ahmedabad Jurisdiction only.

#### ARTICLE - 27: PAYMENT TERMS

- Payment to the Successful Bidder for Design / supply / services / Construction under this Contract / Agreement shall be made as per mentioned in the tender document. The Agency / Contractor / Supplier / Manufacturer shall have to submit the Invoice and detailed Inspection report along with all the supporting documents of work completed duly validated by NTIEM appointed Third Party Quality Assesment Agency. In case of unavoidable circumstances if the authority fails to make payment in time the Bidder will not ask for any interest for the delay period. The Bidder shall continue providing its services / Scope of Supply up to the time period or up to agreed BOQ, requested by the authority. The rate quoted by the bidder in the financial bid will be remain firm and no deviation will be accepted till the completion of the Contract / Agreement / Scope of Supply. No additional payment will be made for auxiliary items like preparation of reports, printing, binding, transportation expense of the team, etc.

#### ARTICLE - 28: RECOVERY OF ADVANCE PAYMENT

- Successful bidder will be asked to provide the equivalent amount of to be supply as Guarantee against advance payment. The successful bidder will be free to provide advance payment guarantee against advance payment as per the payment terms by way of Bank Guarantee or by way of Demand Draft after signing the Contract / Agreement and providing Security Deposit but before taking the advance as per payment terms.
- In case the successful bidder provides bank guarantee against the advance payment guarantee, the validity of bank guarantee should be 180 days beyond the expiry of the Contract / Agreement period.
- The said guarantee against advance payment shall be returned within 30 days period from the actual date of receipt of complete material as per BOQ / product at site and to the satisfaction of the Authority for the execution of the work / settlement of disputes if any.
- The said guarantee will indemnify the authority to recover the advance along with Security Deposit in case the successful bidder fails to supply the product as per the tender terms and conditions.
- The authority may levy the liquidate damage charges as mentioned in article 34 of this tender document regarding the timely supplying the product as per tender terms and conditions.
- Any delay in Design, Supply, Erection, Installation, Commissioning and trial run will attract liquidation damage as per mentioned in tender document.
- The Authority decision will be final and binding to successful bidder.

#### ARTICLE -28: PATENT RIGHTS

- The Bidder shall indemnify the Authority against all third-party claims of infringement of patent, trademark/ copyright arising from the use of services or any part thereof.

#### ARTICLE -30: AUTHORITY'S RIGHT TO AWARD CONTRACT / AGREEMENT TO ONE OR MORE BIDDERS

- Authority reserves the right to award the Contract / Agreement to one or more Bidders and split the order among different Bidders

#### ARTICLE - 31: CONTRACT / AGREEMENT PERIOD

- The Design, Supply, Erection, Installation, Commissioning and Trial Run under the bid document shall commence from the date of signing of the Agreement and shall continue thereafter till the project complete.

#### ARTICLE -32: BIDDER'S OBLIGATION

- The Bidder shall appoint at least 1 authorized person not lower than the rank of Senior Manager as "Coordinator" to co-ordinate with the Authority in all matters related to the Contract / Agreement for the successful implementation and operation of the project and to be responsible for all necessary exchange of information.
- The Bidder shall provide all assistance to the Authority representative/s as they may reasonably require for the performance of their duties and services.
- The Bidder and their Contract / Agreementor working at project site shall be responsible for all statutory obligations/ liabilities like Salary, ESI, PF, Personnel Insurance, etc. The Bidder shall abide by all rules & regulations from time to time such as Minimum Wages Act, Labour Laws, etc. for the manpower employed by it
- The Bidder shall employ at their own cost and expenses sufficient and competent staff with adequate background training and experience as may be reasonably required for the fulfillment of the Bidder's obligations under the agreement and shall give their professional expert guidance and supervision to the work. If in the opinion of the Authority any staff or

manpower of Bidder is found unsuitable, the Bidder shall be liable to change the staff/supervisor forthwith.

- The Bidder shall indemnify Authority against all the losses, injuries and any kind of damage arrived due to its activities.
- The Bidder should comply with all rules and regulations applicable for the fulfillment of the proposed job.
- The Bidder should provide supply / Services uninterrupted and the manpower deployed should follow the instructions given by Authority if any.
- The Bidder shall intimate the Authority about the blacklisting of their firm by any Central / State government body during the Contract / Agreement period due to any reason.
- During the performance of the Contract / Agreement, the quantity / Size of the project may be increased or decreased, due to changes in the estimated quantity of the project due to changes in project phase modifications, revisions in drawings, data sheets, documents, etc. whatsoever reasons. As used herein, the estimated quantity may be increases or decrease by +/- 5% of the overall project cost. In this case, the quoted rate for the project for Design, Supply, Construct, Erect, Install And Trial Run Of Main Air Grid Piping System For Air Distribution ON TURNKEY BASIS Under Capacity Upgradation Project from 100 MLD to 130 MLD facility for textile CETP at Gyaspur, Ahmedabad will be remained firm till the completion of this project. No price escalation will be considered beyond the quoted rate in any conditions/situations that arise during the performance of the project.

#### ARTICLE - 33: AUTHORITY'S OBLIGATIONS

- Grant in a timely manner all such approvals, permissions and authorizations which the Bidder may require or is obliged to seek from in connection with the implementation of the project and the performance of the Bidder obligations.
- Permission, Approval, and Selection of the land & buildings and any statutory clearance regarding ownership of the center are under the scope of authority.
- Authority shall release the funds in a timely manner, after satisfying itself of all the project-related, statutory, and accounting aspects, so as to enable the Bidder to satisfactorily perform its obligations.
- The Authority shall appoint, an authorized person as 'Coordinator – Authority' to coordinate with the Bidder in all matters related to the Authority for the successful implementation of the project and to be responsible for all necessary exchange of information required.
- Authority would constitute an appropriate committee to oversee the functioning of the work.

#### ARTICLE - 34: LIQUIDATED DAMAGES

- In the event of failure of the Bidder to secure Acceptance by the Authority, before the commencement date as prescribed by the Authority, the Authority reserves the option to recover from the Bidder as liquidated damages and not by way of penalty, 100 % of the Total Accepted Tender Value to be rendered for the period after the said commencement date until acceptance without prejudice to other remedies under the Contract / Agreement.
- liquidated damages shall be levied @ 0.75 % of the basic value of material to supply or delay in submission of details / documents / drawings by Manufacturer / Supplier / Contractor per week up to 100 % of the Total Accepted Tender Value for the delay in required submissions by the successful bidder / tenderer. However, the Authority will decide final verdict based on facts and reasons produced along with supporting before him.

#### ARTICLE - 35: SUSPENSION AND TERMINATION OF THE CONTRACT / AGREEMENT

- Authority may, by a written notice of suspension to the Bidder, suspend the Contract / Agreement if the Bidder fails to perform any of its obligations under this Contract / Agreement (including the carrying out of the supply / services) provided that such notice of suspension:
  - Shall specify the nature of the failure and
  - Shall request the Bidder to make rectification of such failure within a specified period from the date of receipt of such notice of suspension by the Bidder.
  - During the suspension period, bidders can carry out only rectification activity.
- At any time during the Contract / Agreement Period, / after completion of time duration in suspension notice to rectify and bidder fail in executing rectification, Authority has the right to cancel the Contract / Agreement after giving a notice of one week in writing by way of letter to registered office address or by email as provided in bidder profile, if the Bidder commits a breach of any or all conditions of the Contract / Agreement and tender document and fails to remedy the breach within the time frame provided by the Authority. Breach of Contract / Agreement includes, but is not limited to, the following:
  - The Bidder stops work and such stoppage has not been Authorised by the Authority.
  - The Bidder may become bankrupt or goes into liquidation other than for project or amalgamation.
  - Authority gives the notice to correct a particular defect/ irregularity affecting performance and the Bidder fails to correct such defects/ irregularity to achieve performance within a reasonable period of time determined by the Authority.
  - The Bidder is found to act in the selfish interest and not in the interest of the beneficiaries.
  - Serious misconduct / accident on part of the Bidder.
  - The registration of the Bidder with any statutory registration agency of Government of India, Government of Gujarat, The Institute of Chartered Accountants of India or The Institute of Company Secretaries of India gets canceled due to any reason.
  - Failure of Bidder in intimating the authority of its blacklisting by any central/state government body, the authority reserves the right to terminate the Contract / Agreement.
- If the Contract / Agreement is terminated by the Authority unilaterally, the Authority will pay to the Bidder the remaining amount, if any, for the payment for Supply / Service charges along with necessary taxes and duties as agreed in price for agreement, for the period for which the service or to the extend supply has been rendered and all other claims through mutually agreeable settlement.
- The authority reserves the right to terminate the Contract / Agreement from their side after giving a one-month notice period without assigning any reasons at its discretion. Nothing contained in this clause shall restrict in any manner the right of NTIEM to recover the liquidated damages from the bidder upon termination of contract due to breach of contract by the bidder.

#### ARTICLE - 36: "NO CLAIM" CERTIFICATE

- The Bidder shall not be entitled to make any claim, whatsoever, against the Authority, under or by virtue of or arising out of this Contract / Agreement, nor shall the Authority entertain or consider any such claim, if made by the Bidder and the Bidder shall have signed a "No Claim"

Certificate in favor of the Authority in such forms as shall be required by him after the works are finally accepted.

#### ARTICLE -37: OWNERSHIP OF DATABASE AND ASSET

- The ownership of the database as and when created in the course of the execution of the work under this tender during the Contract / Agreement period without any liability will be automatically transferred to Authority. None of the physical facility and manpower created under this tender shall be transferred to Authority at the end of the Contract / Agreement Period, except the capital expenditure made by the Authority.

#### ARTICLE - 38: DETAILS TO BE KEPT CONFIDENTIAL

- The successful bidder has to sign a binding non-disclosure agreement with Authority.

#### ARTICLE - 39: TRANSFER OF RIGHTS

- The Bidder shall not transfer the Contract / Agreement to anybody except with the prior permission of the Authority.

#### ARTICLE - 40: IMPLEMENTATION SCHEDULE

- The Bidder is required to commence operations as per scope of activities from the date of signing of Work Order/ Letter of Acceptance.

#### ARTICLE - 41: REGARDING CONTRACT / AGREEMENT LABOUR and SAFETY LAWS:

- The Manufacturer / Supplier / Contractor / Agreementor / Agency will be solely responsible to disbursed wages to their staff / labour through Bank and they will strictly follow the Minimum Wages Act 1948. Furthermore, the Manufacturer / Supplier / Contractor / Agreementor / Agency will be solely responsible for their employees' "Bonus" as well as any violation of the provision of the Minimum Wages Act shall render the Contract / Agreement liable for termination.
- The successful bidder shall be responsible for all injuries and accidents to their employee. The successful bidder shall have to submit the Workman Compensation Policy for the duration of work. The working manpower at site must be covered under the same policy. Any violation will liable for termination of contract.
- The successful bidder shall have to work in accordance with all the present rules and regulations set by Government Agencies and have to immune the NTIEM from such damages.
- The Successful Bidder shall comply with all statutory requirements existing as well as those rules, orders, and notifications promulgated from time to time, viz. the payment of
  - Wages Act 1936,
  - Minimum Wages Act 1948,
  - Maternity Benefits Act, 1951,
  - Employees Provident Fund & Misc. Provision Act 1952,
  - Employee State Insurance Scheme, Family Pension Fund Act, Workman Compensation Act.
  - Payment of Bonus Act 1965,
  - Payment of Gratuity Act 1972,
  - Contract / Agreement Labour (Regulation & Abolition) Act 1970,
  - Equal Remuneration Act 1979,
  - Child Labour (Prohibition and Regulation) Act 1986

- Inter-State Migrant Workmen (Regulation of Employment and Conditions of Service) Act 1979
- Employee's liability Act 1938.

ARTICLE:42 INSURANCE

- Wherever necessary, the goods supplied under the Contract / Agreement shall be fully insured in a freely convertible currency against loss or damage incidental to manufacture or acquisition, transportation, storage, and delivery in the manner specified in the Contract / Agreement. If considered necessary, insurance may cover "all risks" including war risks and strike clauses. The amount to be covered under insurance should be sufficient to take care of the overall expenditure to be incurred by the Procuring Entity for receiving the goods at the destination.



## PROJECT BACKGROUND AND SCOPE OF WORK IN BRIEF

### Introduction

#### 1. Project Brief:

Design, Supply, Construct, Erect, Install And Trial Run Of Main Air Grid Piping System For Air Distribution ON TURNKEY BASIS Under capacity Upgradation Project from 100 MLD to 130 MLD facility for textile CETP at Gyaspur, Ahmedabad.

#### 2. Detailed Project Study:

The Manufacturer / Supplier / Contractor shall carry out a detailed study of other existing plant and assess the requirements for successful implementation of the upgradation project. (A Detailed RFQ is attached herewith for understanding with supporting data in the same chapter at the end. This is indicative and can be helpful in offering the product and filling the bid document.)

#### 3. Location:

NTIEM - CETP  
Part 34, Nr Animal Foundation,  
Gyaspur, Narol,  
Ahmedabad.382405 Gujarat,  
Location: <https://goo.gl/maps/mBy5ZWbzBaEkkjCc6>

#### 4. Project Composition:

Private Sector

#### 5. Project Cost:

The total estimated project cost for Entire upgradation project is about 12500 Lacs

#### 6. Project Funding:

The SPV has already applied for Financial Assistance from the Office of Industries Commissioner, Government of Gujarat under industrial policy 2020. The rest of the funding shall be met through Term Loan, Internal Accruals and funds brought in by the members of the SPV.

#### 7. Scope of Supply and Services:

The Manufacturer / Supplier / Contractor shall Design, Supply, Construct, Erect, Install And Trial Run Of Main Air Grid Piping System For Air Distribution On Turnkey Basis Under Capacity Upgradation Project from 100 MLD to 130 MLD facility for textile CETP at Gyaspur, Ahmedabad. The Detailed Scope is also defined in RFQ and to be consider while bidding.

The works will be undertaken as the EPC (Design, Engineering, Procurement, Construction), Turnkey, Contract / Agreement under the control of authority with the help of PMC / Consultant and funds for the works will be obtained from the Government of Gujarat and / or from the Government of India.

The Manufacturer / Supplier / Contractor shall have to work in co-ordination with Third Party Quality Assessment Agency (TPQA) Agency and TPQA will work as Authority's extended arm in monitoring & controlling the activities of the EPC Contractor / Manufacturer / Supplier / Contractor and PMC agency, The project as a whole is monitored by the PMC / Consultant. For the purpose of the implementation

of the work, the Third-Party Inspection including Quality Assurance & inspection of materials shall be the scope of the Third-Party Inspection agency appointed by Authority. However, the Third-Party Inspection Agency will work in co-ordination with PMC/EPC/turnkey Agency and in line with the EPC/turnkey Contract / Agreement requirements for further planning of the projects.

The Authority deployed Third Party Inspection Agency for entire project & construction management, Quality assurance, checking of measurements and inspection of day-to-day work & material being utilized while execution of the projects. The Manufacturer / Supplier / Contractor has to work in coordination to TPQA.

#### Execution Process roadmap and Submissions

- The Manufacturer / Supplier / Contractor has to provide the design calculations, Curves, a detailed BOQ with quantity and MOC / Make to be supplied, GA Drawings, section drawing with level, Detailed manufacturing process, QA and checklist during manufacturing process, Time Schedule for complete Job and civil drawing immediately up on the receipt of the PO/ WO or signing of agreement. Up on getting confirmation on design and Civil drawings, the Authority will confirm the start of manufacturing process.
- Depending upon the process, site visit observations, Manufacturer / Supplier / Contractor has to offer the material or product.
- The Variation in Quantity can be up to +/- 10%. The detailed GA, Plan, Section Drawings are attached herewith for your reference and verification.
- A Detailed list of Deliverables is mentioned in Chapter 6 of RFQ.
- The Manufacturer / Supplier / Contractor has to provide regular updates every 30 days on manufacturing status. Authority himself or by this Authorised representative reserve the right to visit the manufacturing facility to review the progress. Once the material as per BOQ is ready, the manufacture / Supplier will inform the authority for audit and inspection of material. Once the Inspection is clear, the Manufacturer / Supplier / Contractor will dispatch the material to site. Necessary unloading and storing of material will be manage by the Manufacturer / Supplier / Contractor site team or by their Authorised contractor. The Authority will provide the space nearby Installation and Commissioning site for unloading and for Storage of Material during the Installation and Commissioning process.
- The Manufacturer / Supplier / Contractor is not allowed to change / Modify / Altera BOQ, civil drawings and dispatch schedule. In case if such modification is necessary, the Supplier / Manufacturer has to obtain written consent from the Authority. Without the written consent no modification will be accepted.
- The Manufacturer / Supplier / Contractor is instructed to supervise the supporting activity which are out of scopy of PO/WO but directly affecting the installation and functioning of this line supply. The Manufacturer / Supplier / Contractor has to inspect the linked activity which are out of the scope of PO/WO but are supporting in nature, work on stage wise manner and have to give confirmation of the satisfactory work. They also have to ensure that the work is executed as per their provided drawings and inputs. The Authority will not accept any claim which may arise due to improper out of the scope activity but are in supporting of nature. In case of any deviation, it will be

responsibility of the Manufacturer / Supplier / Contractor to report it with Authority in writing as and when they come across.

- The Manufacturer / Supplier / Contractor is also instructed to record videos and photographs during the erection, Installation and Commissioning process. The authority will not allow to take back any material listed in BOQ. However, the excess material brought in by Manufacturer / Supplier / Contractor during the Erection, Installation and Commissioning process will be allowed to take back once the complete job of Design, Supply, Construct, Erect, Install And Trial Run Of Main Air Grid Piping System For Air Distribution On Turnkey Basis is successfully executed and desired performance is achieved. The Manufacturer / Supplier / Contractor has to get approval from Authority to take back the excessive material other than BOQ.
- The entire job of Design, Supply, Construct, Erect, Install And Trial Run Of Main Air Grid Piping System For Air Distribution on turnkey basis as per design and approved parameter will be in the Manufacturer / Supplier / Contractor Scope. The necessary support structure for smooth and efficient operation and routine maintenance for Design, Supply, Construct, Erect, Install And Trial Run Of Main Air Grid Piping System For Air Distribution On Turnkey Basis. like supports, clamps, platforms, stair way, walkways, will be in The Manufacturer / Supplier / Contractor Scope. The necessary tools, tackles, lifting equipment, Hydra, Scaffolding, the personal safety, Commutation, Lodging and Boarding has to be arranged by the Manufacturer / Supplier / Contractor on their own. The Manufacturer / Supplier / Contractor will be provided Space, Water and Power at site without any cost for Erection, Installation and Commissioning work. All the statutory compliance related to contract labour, personal safety and Erection, Installation and Commissioning related insurance for personal and material has to be managed by supplier.
- After Successful Installation, Commissioning and trial run, the Manufacturer / Supplier / Contractor has to provide as built detailed drawings, the as built BOQ with all specifications, MOC, First hand training for basic and routine maintenance activity, Activity Schedule Chart for Routine Inspection and Activity schedule for Preventive Maintenance.

#### Reporting and Co-Ordination:

The Manufacturer / Supplier / Contractor (and their appointed team members) shall report only to the Authority's representative who shall be the sole point of contact with the Manufacturer / Supplier / Contractor / Contractor. The Authority shall also have a senior and supervisory staff of PMC as required at the site. The Manufacturer / Supplier / Contractor shall co-ordinate with all such persons for the fulfillment of obligations, but shall report solely to the Authority's representative.

#### Project Team:

The Manufacturer / Supplier / Contractor shall be required to form a multi-disciplinary Project Team for this assignment, from the areas given below

Senior Person with Civil Background for Supervision on Civil and Structural Part along with subordinates if required.

Senior person with Mechanical and Electrical Background for Installation and Commissioning and Erection part along with subordinates if required.

Senior and Experienced person with Quality Assurance and Quality Control background along with subordinates if required.

Assistance from Authority:

Authority would help in coordinating site visits and also any clarifications sought by Manufacturer / Supplier / Contractor before the Proposals are submitted if possible. The Third-Party Agency would be assisted by authority/PMC in obtaining relevant information from the authorities as well as extensive cooperation in the following areas: a) Exchange of data and information related to the study. b) Day-to-day interactions and management of activities to enable active functioning to facilitate activities related to Assignments and collection of data from State Government Departments and other agencies.

Exclusion list in Scope of Contract.

- Necessary site clearance
- All kind of item supply and Installation and Commissioning work other than the BOQ items for Civil, Electrical, Piping, Instrumentation items and supply and Installation and Commissioning work outside battery limit of scope of work / Supply, other than BOQ
- Emptying of tank / Land etc until and unless specify in the WO/PO.
- Obtaining NOC/ Licence.
- The Workshop facility is not available at site. The Manufacturer / Supplier / Contractor has to manage if any modification / alteration in mechanical component is required.

## RFQ as per mentioned in Scope of Work.

# Narol Textile Infrastructure and Enviro Management Common Effluent Treatment Plant



## CAPACITY AUGMENTATION UP TO 130 MLD FOR CETP

Prepared for: Narol Textile Infrastructure & Environment Management

Prepared by: JM Smith International LLC

This document is an extended part of the Design Project Report. Design Project Report (DPR) document has been developed under an agreement between Narol Textile Infrastructure & Environment Management (NTIEM) based in Ahmedabad, Gujarat, India and (JMSI) based in West Palm Beach, Florida, USA towards the operation and modification/upgrade of the 100 MLD to 130 MLD Common Effluent Treatment Plant (CETP) at Gyaspur, Ahmedabad, Gujarat, India.

The contents of this document have been prepared for distribution to NTIEM on a proprietary and confidential basis for submission of the project report referred under the agreement for the purpose of NTIEM to garner State of Gujarat Government support for funding/grant assistance towards the project upgrade to be implemented by JMSI. By accepting the DPR document, NTIEM agrees not to disseminate the document or content of the document to any other person or entity in any manner and not to use the information for any purpose other than considering opportunities for a cooperative business relationship with JMSI.

This DPR document is the property of JMSI. No part of this document, including all original concepts and ideas contained herein, both technical and commercial, may be reproduced or transmitted in any form, or by any means, electronic or mechanical, for any purpose without the express written permission of JMSI.

NTIEM shall utilize the technical and commercial content of the DPR document within the agreement made with JMSI and for implementation of the operation and upgrade of the project.

The DPR document further falls under the NDA executed between NTIEM and JMSI.

## CONTENTS

	Name
	Introduction to NTIEM CETP
	Inlet Parameters since January 2020
	Inlet Parameters Table 2.1
	Outlet Parameters Table 2.2
	Comparison of change in the inlet parameters with respect to Consent to Operate
	Comparison Table: Design Inlet Parameters Mentioned in Consent To Operate v/s Actual Design Inlet Parameters at Present
	Design Inlet Parameters chosen for CETP upgradation and modifications
	Design, Supply, Construct, Erect, Install And Trial Run Of Main Air Grid Piping System For Air Distribution On Turnkey Basis. Specifications and request for quotations from vendors

## CHAPTER 1 - INTRODUCTION TO NTIEM 100 MLD CETP

Narol Textile Infrastructure and Enviro Management Common Effluent Treatment Plant (NTIEM CETP) is a 100 MLD secondary treatment system built to cater to the effluent treatment demand of its 124 member units located in the Narol area in Ahmedabad. NTIEM Common Effluent treatment plant was conceived and constructed to treat wastewater from several textile mills near Ahmedabad and to provide safe discharge of treated wastewater in Sabarmati River.



NTIEM CETP Primary Treatment in Precipitating Clarifiers. It is divided into four trains of 25 MLD each which has four equalization tanks and four primary clarifiers.

The biological treatment approach is provided as a Continuous Flow Integral Clarifier Activated Sludge System (CFICASS), which is an advanced form of conventional activated sludge. The CFICASS can sustain higher biomass levels than conventional activated sludge and has no moving parts in contact with effluent.

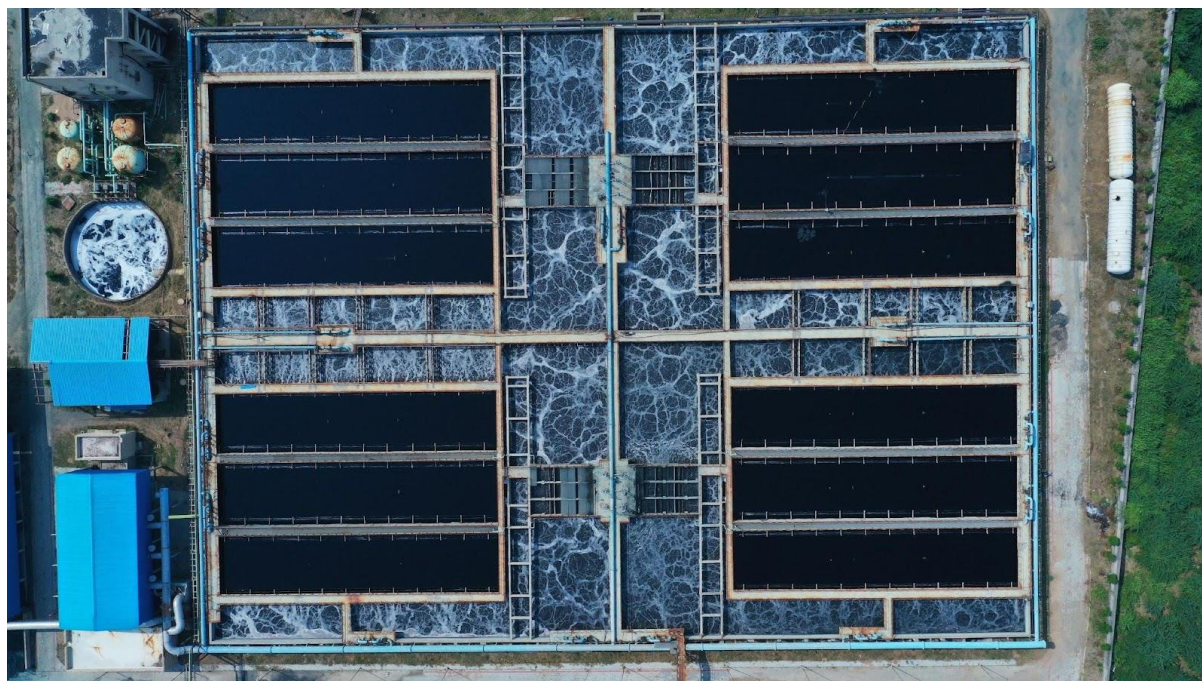

The CFICASS incorporates the secondary clarifier into the aeration tank in the form of rows of 60-degree sloped wedges. Sludge recycling is accomplished using airlift pumps. Biomass is conditioned prior to clarification to enhance floc formation and remove scum or foam. The clarifier uses an induced downward velocity to separate the treated effluent from the mixed liquor, which is recycled back to the aeration tank at the bottom of the clarifier by gravity. The carry-over of biomass from the integral clarifiers is very low and can be further reduced by adding suitable settling polymer in a static biomass conditioning system. There are no moving parts in contact with effluent in the entire CFICASS system; as a result, this system has a low maintenance requirement.

This system also employs a maintenance-free engineered orifice coarse bubble aeration system. At the selected 9-meter liquid depth, this option provides aeration efficiency comparable to that of fine-bubble diffusers.

The four CETP CFICASS tanks include three integral clarifiers, providing an overflow rate of 0.68 meters per hour at the average flow. The configuration of the clarifiers is designed to segment each CFICASS tank into three aeration zones. The influent water enters the first zone (Zone 1), where it is blended with return activated sludge from the Integral Clarifiers. There are two, parallel Zone 1's per CFICASS tank. An internal recycle air lift pump is provided in each Zone 1, to transfer biomass from the end of each Zone 1 back to the head of that Zone 1 to mix with the influent wastewater.

The mixed liquor from each Zone 1 flows under the Integral Clarifiers to Zone 2. There are two Zone 2's per CFICASS tank. At the end of each Zone 2, the mixed liquor flows into Zone 3. There is one Zone 3 per CFICASS tank. The clarifier airlift pump is located in Zone 3 to recirculate the mixed liquor back



to Zone 1 via the Integral Clarifiers. The purpose of the three-zone design is to provide enhanced biological treatment and improved aeration efficiency by designing for increased biological removal rates in Zones 1 and 2, while Zone 3 is designed to provide effluent polishing.

The air grids in each zone are designed based on the expected oxygen requirements for that zone and a Dissolved Oxygen control system is provided to optimize the power consumption. There are three aeration blowers (two operating and one spare), common between all four CFICASS units, to provide aeration for meeting oxygen and mixing requirements. Aqueous ammonium hydroxide and phosphoric acid are added to each Zone 1 in order to meet nutrient requirements for biological growth.

The treated effluent will flow by gravity to final outfall and the same is to be also used for the chemical makeup and belt washing purpose by passing through sand and carbon filters. Waste activated sludge shall be continuously withdrawn from the clarifier underflows and transferred to the Secondary Sludge Dewatering System.

## CHAPTER 2 - PARAMETERS SINCE JANUARY 2020

TABLE 2.1 - INLET PARAMETERS (MONTHLY AVERAGE)

Month	Average Inlet Effluent (KLD)	Average Inlet Temperature (deg C)	Average Inlet pH	Average Inlet COD (mg/L)	Average Inlet TDS (mg/L)	Average Inlet TSS (mg/L)	Average Inlet TAN (mg/L)	Average Inlet BOD (mg/L)	Average Inlet COLOR (Pt. Co.)
Jan-20	74.4	38.4	7.83	1318	3982	720	60.0	277	722.0
Feb-20	80.6	40	7.93	1441	3891	745	49.7		681.0
Mar-20	54.8	40.2	7.81	1331	3900	737	50.6	688	390.9
Apr-20	3.8		8.08	391	2881	294			319.3
May-20	7.0	40.5	8.37	771	3379	181	56.2	260	407.1
Jun-20	40.1	38.5	8.18	948	2884	432	38.5	424	492.8
Jul-20	61.7	43.95	7.79	1061	3044	583	44.6	366	592.6
Aug-20	73.3	39.1	7.92	1122	3171	625	51.2	598	653.1
Sep-20	84.9	40.7	8.02	1283	3446	732	50.5	748	702.2
Oct-20	86.3	41.5	8.30	1361	3705	742	45.0	380	682.3
Nov-20	64.1	37.9	8.31	1338	3681	959	41.7	285	821.2
Dec-20	90.7	37.5	8.30	1403	3754	740	47.5	220	649.4
Jan-21	91.8	38.6	8.26	1432	3785	829	46.2	360	703.2
Feb-21	95.3	39.5	8.10	1437	3848	921	46.0	302	693.0
Mar-21	87.9	41	8.20	1487	4225	798	50.9	196	666.7
Apr-21	80.3	42.2	7.94	1487	3965	860	50.3	183	575.9
May-21	42.4	41.2	7.62	1067	3985	717		272	477.0
Jun-21	66.5	42.5	7.72	1094	3845	826	39.7	210	479.5
Jul-21	77.6	42.2	7.65	1138	3657	861		276	539.6
Aug-21	85.3	41.5	7.52	1197	3650	854	28.6	327	640.5
Sep-21	96.3	41.3	7.36	1169	3459	811	28.4	426	648.7

Month	Average Inlet Effluent (KLD)	Average Inlet Temperature (deg C)	Average Inlet pH	Average Inlet COD (mg/L)	Average Inlet TDS (mg/L)	Average Inlet TSS (mg/L)	Average Inlet TAN (mg/L)	Average Inlet BOD (mg/L)	Average Inlet COLOR (Pt. Co.)
Oct-21	79.2	41.4	7.91	1264	3619	831			708.1
Nov-21	70.6	40.1	7.84	1240	3570	925		125	851.6
Dec-21	93.6	39.6	7.67	1281	3688	877	38.6	344	665.3
Jan-22	89.2	39.1	7.87	1317	3717	898	46.5	183	696.4
Feb-22	90.6	39.8	8.00	1366	3783	884		419	748.8
Mar-22	84.1	40.9	7.84	1466	3763	1123	35.6	410	849.7
Apr-22	89.1	41.5	7.72	1513	3941	1077		537	786
May-22	80.7	42.1	7.9	1536	3806	680	44.2	559	857.5
Jun-22	85.0	41.8	8.16	1356	3779	854	36	788	589.6
Jul-22	89.7	40.9	8.18	1353	3537	856	34.6	440	571.2
Aug-22	84.6	41.0	8.21	1337	3678	395	35.5	238	674
Sep-22	86.7	41.1	7.80	1297	3532	365	37.1	412	706.4
Oct-22	62.3	40.6	7.78	1286	3375	317	25.9	213	644.3
Nov-22	77.3	39.8	7.63	1409	3623	321	36.6	324	773.3
Dec-22	83.9	39.0	7.85	1380	3823	328	36.6	304	835.3
Jan-23	90.3	39.1	7.69	1332	3742	323	43.4	278	761.5
Feb-23	94.4	39.5	7.65	1416	3618	344	47.3	355	760.3
Mar-23	90.5	39.5	7.68	1404	3469	325	45.1		696.3
Apr-23	92.7	40.1	7.45	1514	3552	328	37.2	317	715.5
<b>Average of Averages</b>	<b>76.49</b>	<b>40.39</b>	<b>7.90</b>	<b>1283.58</b>	<b>3643.80</b>	<b>675.45</b>	<b>42.60</b>	<b>362.33</b>	<b>660.73</b>

TABLE 2.2 - OUTLET PARAMETERS (MONTHLY AVERAGE)

Month	Average Outlet Effluent (KLD)	Average Outlet Temperature (deg C)	Average Outlet pH	Average Outlet COD (mg/L)	Average Outlet TDS (mg/L)	Average Outlet TSS (mg/L)	Average Outlet TAN (mg/L)	Average Outlet BOD (mg/L)	Average Outlet COLOR (Pt. Co.)
Jan-20	74.2	37.3	8.04	270	4006	94	31.8	45.0	285.4
Feb-20	78.5	37.9	7.90	166	3895	52	18.7	0.0	197.1
Mar-20	53.4	39.1	7.90	124	3778	17	13.9	47.0	182.5
Apr-20	1.7	0	8.14	94	3740	17	0.0	0.0	168.0
May-20	3.9	0	8.51	155	3123	52	1.9	48.0	199.8
Jun-20	46.4	0	8.20	96	2851	30	5.4	35.2	168.3
Jul-20	68.2	0	8.40	110	3029	27	18.3	34.2	203.9
Aug-20	66.5	0	7.94	111	3144	22	17.7	33.8	204.2
Sep-20	76.0	0	8.01	128	3509	32	25.1	32.3	206.5
Oct-20	81.0	0	7.98	131	3768	26	18.0	34.2	186.5
Nov-20	59.2	0	7.94	126	3778	44	16.2	31.1	199.4
Dec-20	88.4	0	8.03	159	3855	44	36.3	30.7	224.7
Jan-21	90.0	0	7.95	182	3813	53	38.7	32.2	228.6
Feb-21	94.4	0	8.03	168	4005	42	47.1	26.8	221.4
Mar-21	87.1	0	8.00	151	4204	42	33.6	29.6	210.4
Apr-21	79.4	0	7.95	130	3987	38	31.3	11.0	188.0
May-21	41.9	0	7.98	108	3906	20	0.0	13.0	131.6
Jun-21	65.9	0	7.80	185	3952	37	2.9	16.0	195.8
Jul-21	77.0	40.5	7.80	161	3704	35	0.0	19.5	203.5
Aug-21	84.0	40.2	7.74	117	3601	36	23.0	19.0	217.0
Sep-21	95.5	40.1	7.60	135	3455	34	19.9	28.0	196.1
Oct-21	79.1	40.3	8.04	141	3654	41	16.0	26.0	204.6

Month	Average Outlet Effluent (KLD)	Average Outlet Temperature (deg C)	Average Outlet pH	Average Outlet COD (mg/L)	Average Outlet TDS (mg/L)	Average Outlet TSS (mg/L)	Average Outlet TAN (mg/L)	Average Outlet BOD (mg/L)	Average Outlet COLOR (Pt. Co.)
<b>Nov-21</b>	68.9	39.2	8.01	144	3624	43	0.0	18.0	244.7
<b>Dec-21</b>	93.5	37.2	7.97	156	3699	40	33.9	30.5	219.2
<b>Jan-22</b>	88.3	36.5	7.96	182	3801	49	38.9	19.0	212.1
<b>Feb-22</b>	89.8	37.5	8.13	195	3843	90	0.0	31.0	261.7
<b>Mar-22</b>	83.2	38.8	8.05	221	3812	138	18.0	30.7	302.4
<b>Apr-22</b>	88.3	39.7	8.12	168	3851	80	0.0	28.8	277.7
<b>May-22</b>	80.0	40.3	8.09	168	3820	70	17.6	25.0	272.6
<b>Jun-22</b>	84.0	40.8	8.09	171	3735	65	24.9	27.0	249.1
<b>Jul-22</b>	88.9	39.3	8.30	119	3505	42	19.6	34.5	169.4
<b>Aug-22</b>	83.8	39.7	8.35	109	3594	33	14.7	18.0	184.9
<b>Sep-22</b>	85.9	40.3	8.05	106	3494	32	10.0	19.5	188.1
<b>Oct-22</b>	61.8	39.5	8.14	108	3429	34	6.0	18.0	186.8
<b>Nov-22</b>	76.6	38.1	8.21	125	3547	41	13.2	19.0	191.3
<b>Dec-22</b>	83.0	36.7	8.10	114	3699	36	10.5	24.0	194.8
<b>Jan-23</b>	89.5	35.8	8.10	121	3720	35	15.8	25.5	198.8
<b>Feb-23</b>	93.3	37.5	8.08	142	3650	38	21.1	23.0	203.3
<b>Mar-23</b>	89.6	38.6	8.13	180	3577	71	35.9	26.0	238.3
<b>Apr-23</b>	93.9	39.8	8.02	197	3617	50	38.4	23.0	230.7
<b>Average of Averages</b>	75.4	24.27	8.04	146.85	3669.35	45.55	18.36	25.83	211.23

## CHAPTER 3 - COMPARISON OF CHANGE IN THE INLET PARAMETERS WITH RESPECT TO CONSENT TO OPERATE

---

Textile industry in India is one of the largest employers after agriculture and is an industry driven by continuously evolving market demands. Textile industries in Ahmedabad have a significant share in satisfying the domestic textile demand as well as exports. The consent to establish for NTIEM CETP was granted in Year 2011 and consent to operate was granted in year 2017. The permissible parameters in CETP inlet mentioned in the consent to establish and consent to operate are the same.

As there have been several changes in the type of products being manufactured over the last decade, water consumption in production, types of chemicals used in production and manufacturing equipment, there have been gradual changes in the inlet quality of effluent to the NTIEM CETP.

Table 2.1 describes the monthly average of inlet parameters from January 2020 to June 2021. Table 3.1 describes the overall average of inlet parameters in comparison to parameters mentioned in the consent to operate.

Based on the tabular and graphical data comprehensions, it is evident that the inlet effluent quality gets concentrated once the inlet quantity is consistently above 70 MLD. The change in the inlet quality with respect to inlet quantity is because of factors related to textile production only.

Based on the proactive policies of Government of India and Government of Gujarat, there is an anticipation of a significant increase in textile production which will be directly proportional to the hydraulic load of effluents being discharged from the CETP.

The revised inlet parameters have been determined on the basis of the above thematic indicators and associated process variables.

### 3.1 COMPARISON TABLE: DESIGN INLET PARAMETERS MENTIONED IN CONSENT TO OPERATE V/S ACTUAL DESIGN INLET PARAMETERS AT PRESENT

TABLE 3.1 - COMPARISON - INLET PARAMETERS AS PER CCA & ACTUAL

Parameters	Unit of Measurement	As per Consent to Operate	Actual Inlet Parameters
pH	--	6.5 - 8.5	8.03
Total Dissolved Solids	mg/L	2100	3660
Total Suspended Solids	mg/L	300	719
Temperature	°C	40	42
Chemical Oxygen Demand	mg/L	1200	1248
BOD (at 27° C for 3 days)	mg/L	500	491
Total Ammoniacal Nitrogen	mg/L	50	48
Oil & Grease	mg/L	10	<10
Color	PtCo	100	627

### 3.2 DESIGN INLET PARAMETERS CHOSEN FOR CETP UPGRADATION AND MODIFICATIONS

TABLE 3.2 - DESIGN INLET PARAMETERS CHOSEN FOR UPGRADATION

Parameter	Unit of Measurement	Inlet	Outlet
Flow	KLD	1,30,000	1,30,000
pH		7.5 - 9	6.5 - 8
BOD	mg/L	600	<30
COD	mg/L	1500	<200
TSS	mg/L	1000	<100
TDS	mg/L	5000	5000
TAN	mg/L	130	<50
TKN	mg/L	200	<100
Heavy Metals	mg/L	Within limits	Within limits
Temperature	Deg C	43	35



## CHAPTER 4 - DESIGN, SUPPLY, CONSTRUCT, ERECT, INSTALL AND TRIAL RUN OF MAIN AIR GRID PIPING SYSTEM FOR AIR DISTRIBUTION ON TURNKEY BASIS

### SPECIFICATIONS AND REQUEST FOR OFFER FROM VENDOR

Based on technology selection, reputed vendors were invited for onsite discussions and the same was followed by pilot testing on site. Below are the pilot testing results performed on site from respective vendors

Following are inferences and design specifications:

#### 1. List Of Deliverables with Offer

- Technical Offer to include:
  - Process sizing calculations.
  - Technical data sheets and product catalogs with performance specifications (including for ancillary equipment and components used for).
  - Preliminary layout clearly identifying all units and associated equipment, including all pipework etc.
  - Indicative BOQ of items with approximate quantity with MOC included in offer.
  - Vendor should suggest MOC
  - Exclusion list.
  - Company profile.
  - Reference list including size of project, scope of supply, and reference contact information.
  - The Supplier/Manufacturer must have ISO-9001 certification for QMS & 14001 for environment management system. Having one of their ranges of product as CTI certified will be an added advantage. Also attach copy of certification.
  - Payment terms.
  - Delivery / Construction lead time.
  - Offer validity.
  - Performance guarantee.
  - Testing certificates of all welded joints,
  - All material suppliers test certificates.
  - Complete equipment test certificate.
  - Ability to offer third party inspection.
- Commercial Offer to Include:
  - Price for Design, core supply of Design, Supply, Construct, Erect, Install And Trial Run Of Main Air Grid Piping System For Air Distribution On Turnkey Basis job on a “FOR” Site basis with operating installation, along with price for:
    - Ancillary equipment (valves, accessories) broken apart by line-item for each equipment.
  - Price Bid (Part II of Tender Document.)

#### 2 Scope of Contract

Vendor offer shall include the following equipment and services in their scope of Contract:

- Study of the present design if any and proposed design parameters.
- Vendor submission package (to be approved prior to equipment being manufactured/shipped):
  - Basis of Design.
  - Process sizing calculations.
  - Electrical, Piping and Instrumentation Diagram (P&ID).
  - To-scale equipment general arrangement drawings with Installation and

- Commissioning details for the equipment proposed for this project.
- Design, Procure, Supply, Construct / Erection include entire job supervision
  - Approved vendor submission package to be submitted in both hard and soft copy.
  - Supply at “FOR” Site including Loading, Packing, Forwarding, Freight, Insurance, unloading at site
  - Optional supply of ancillary equipment, including:
    - Any other ancillary equipment necessary for a fully functional Design, Supply, Construct, Erect, Install And Trial Run Of Main Air Grid Piping System For Air Distribution On Turnkey Basis. system (e.g., valves, accessories, etc.).
    - Critical spares for commissioning
    - Provision of supervision of Installation and Commissioning

### **3 General Requirements**

#### Technical information

A complete technical description (specification, design calculations and Curves, catalogues, dimension, working data, etc.) of the equipment and/or materials proposed shall be submitted separately. There shall not be any reference to commercial and price information in such technical information and data.

#### Packing

Equipment and / or materials shall be supplied with suitable packing for sea / road transportation and for a long period of storage. If required, Vendor to furnish details about any special / specific storage requirement at site.

#### Delivery Terms

The project site is located in Narol, Gujarat, India. All delivery terms shall be read in conjunction “FOR” Site – Packing, loading, Unloading, forwarding, freight & Insurance, Installation and Commissioning etc.

#### CatLog and Reference List

One (1) copy of specific Brochure shall be submitted, referring to the type and model proposed. A list of references shall also be submitted.

#### Deviations and Comments

If there are any deviations to the specifications enclosed, the same shall be clearly stated. Otherwise, it will be assumed that Vendor has no deviations and the vendor is responsible for fulfilment of the requirements.

#### Language and Prices

The offer and all the documentation shall be in English. Vendor shall indicate the currencies, in which the offer is quoted. Vendor shall also indicate the Country of Origin of the equipment. For equipment supplied from outside India, the prices shall include all taxes, levies and duties applicable at the country of origin.

#### Quality Assurance

The materials covered by these specifications are intended to be standard equipment of proven reliability and as manufactured by a reputable manufacturer having experience in the production and Erection of Pipeline. The product furnished shall be designed and constructed in accordance with the best practices and methods and shall operate satisfactorily when installed and operated per the manufacturer’s recommendations.

## CHAPTER 5 – PROCESS REQUIREMENT FOR DESIGN, SUPPLY, CONSTRUCT, ERECT, INSTALL AND TRIAL RUN OF MAIN AIR GRID PIPING SYSTEM FOR AIR DISTRIBUTION ON TURNKEY BASIS

TABLE 6.1 - PROCESS REQUIREMENTS FOR DESIGN, SUPPLY, CONSTRUCT, ERECT, INSTALL AND TRIAL RUN OF MAIN AIR GRID PIPING SYSTEM FOR AIR DISTRIBUTION ON TURNKEY BASIS.

Subject	Input
Waste Water Quality	Textile processing
Total Number of CFICASS	4
Total Flow to Each CFI	24500 NM <sup>3</sup> / HR @ 1.2 bar
Layout and Distribution modality	In Vendor Scope
MOC	Vendor to Suggest
Duty Condition	In Open area and continuous
Instrumentation, Flow Measuring and control Mechanism	Vendor Scope
Support Structure including civil foundation	Vendor Scope

### Minimum Qualification Criteria for the Design, Supply, Construct, Erect, Install And Trial Run Of Main Air Grid Piping System For Air Distribution On Turnkey Basis suppliers

- The supplier must demonstrate the ability to offer local aftersales support in Gujarat, India, including sufficient spares stock facility in the region.
- Supplier should have executed similar or larger sized projects for at least 1 project and these must be working satisfactorily for at least 2 years. Reference list with contact information to be provided.
- Supplier should give a standard warranty of minimum 3 years of their products.
- Local parties/manufacturers need to submit foreign collaboration/partner's certificate with the bid reference to the Narol CETP project.

TABLE 6.2 - TECHNICAL PARAMETERS FOR DESIGN, SUPPLY, CONSTRUCT, ERECT, INSTALL AND TRIAL RUN OF MAIN AIR GRID PIPING SYSTEM FOR AIR DISTRIBUTION ON TURNKEY BASIS.

DESCRIPTION	SPECIFICATION	VENDOR CONFIRMATION
User Location	Narol, Gujarat	
Industry	Wastewater from Textile Industry	
WWTP	CETP – Common Effluent Treatment Plant	
Inlet Air Temperature	Up to 130°C	
Inlet Wastewater flow in Each Lamella Converted Primary Clarifeir	1355 KL/Hr	
Total Numbr of CFICASS Tank	Total 4 Nos	
Components and MOC	Reputed make standard size	
Total Number of Downtake	7 in each CFICASS	
Design Ambient Temperature	50°C	
Protection Design	Vendor Scope	
Interlinking of Operations	Vendor Scope	
Provision for Bypass	Vendor Scope	
Distribution Mechanism	Equally in all 4 CFICASS tanks	

**PRICE BID**

SR No	Description	Sub Head	UOM	Qty	
1	DESIGN, SUPPLY, CONSTRUCT, ERECT, INSTALL AND TRIAL RUN OF MAIN AIR GRID PIPING SYSTEM FOR AIR DISTRIBUTION ON TURNKEY BASIS AS PER BOQ UNDER TEXTILE EFFLUENT CETP CAPACITY UPGRADATION FROM 100 MLD TO 130 MLD PROJECT AT GYASPUR, AHMEDABAD. (PLEASE ATTACHED SEPARATE SHEET ALONG WITH RATE OF EACH UNIT ITEMS AND ESTIMATED QUANTITY)	Basic Value	in INR	1 Lot	
		GST Rate	in %		
		GST Amount	in INR		
		Sub Total A	in INR		
<b>Total</b>		A	in INR		

Amount in Words: Indian Rupees

\_\_\_\_\_ )

**Important Notes:**

- Price Bid shall be filled in Amount only. Price Bid submitted in other mode will be straight way rejected without any intimation. The Bidder has to provide detailed breakup of price bid value in separate sheet along with price bid. The price breakup should be as per the BOQ.

(This amount is inclusive of all the direct and indirect taxes including GST and Necessary TDS will be deducted as per prevailing notifications where ever it is applicable.)

Tenderer's Signature with Seal,

Name in Full

Address, Mobile Number, Email ID:

## Profile of Bidder

SR No	Particulars	Details
1	Name of Organization with unique registration number.	
2	Nature of Organization	
3	Address with Phone Number and Email	
4	Name of Authorised Person	
5	Phone Number and Email of Authorised Person	
6	Pan Number of Organization	
7	GST Number of Organization	

## Contract / Agreement

This agreement, made on the \_\_\_\_\_ (date), between M/s Narol Textile Infrastructure & Enviro Management (Tenderee) and \_\_\_\_\_

\_\_\_\_\_ [name and address of Manufacturer / Supplier / Contractor / Agreementor] (hereinafter called “the Contractor/ Agreementor / The Supplier / The Manufacturer”) of the other part.

Whereas the tenderee is desirous that the Manufacturer / Supplier / Contractor / Agreementor execute **NTIEM/130MLD/Dec/004-2023** (Bid Ref No.) for Design, Supply, Construct, Erect, Install And Trial Run Of Main Air Grid Piping System For Air Distribution On Turnkey Basis Under capacity Upgradation Project from 100 MLD to 130 MLD facility for textile CETP at Gyaspur, Ahmedabad. (here in after called “the Works/ Project”) and the tenderee has accepted the Bid by the Manufacturer / Supplier / Contractor / Agreementor for the execution and completion of such Works and the remedying of any defects therein, at a Contract / Agreement price

of Rs. \_\_\_\_\_ (Rs \_\_\_\_\_ )

NOW THIS AGREEMENT WITNESSES as follows:

1. Tender document is part of this agreement.
2. In this Agreement, words and expression shall have the same meanings as are respectively assigned to them in the Conditions of Contract / Agreement hereinafter referred to, and they shall be deemed to form and be read and construed as part of this Agreement.
3. In consideration of the payments to be made by the Tenderee to The Manufacturer / Supplier / Contractor / Agreementor as hereinafter mentioned, The Manufacturer / Supplier / Contractor / Agreementor hereby covenants with the Tenderee to execute and complete the Works and remedy any defects therein in conformity in all aspects with the provisions of the Contract / Agreement.
4. The Tenderee hereby covenants to pay the The Manufacturer / Supplier / Contractor / Agreementor in consideration of the execution and completion of the Works and the remedying the defects wherein the Contract / Agreement Price or such other sum as may become payable under the provisions of the Contract / Agreement at the times and in the manner prescribed by the Contract / Agreement.
5. The following documents shall be deemed to form and be read and construed as part of this Agreement, viz.:
  - i) Letter of Acceptance;
  - ii) Manufacturer / Supplier / Contractor Bid;
  - iii) Contract / Agreement Data;
  - iv) Conditions of Contract / Agreement (including Special Conditions of Contract / Agreement if any);
  - v) Specifications;
  - vi) Drawings;
  - vii) Reports and Certificates,

viii) Any other document listed in the Contract / Agreement Data as forming part of the Contract / Agreement.

In witness whereof the parties hereto have caused this Agreement to be executed the day, Month and year first before in witness whereof the parties here to have caused this Agreement to be executed the day, Month and year first before written.

For Narol Textile Infrastructure & Enviro Management

Signed by Mr. J K Vyas (CEO) in the presence of the following witnesses.

Binding Signature of Tenderee:

(Authorized Signatory for Affixing Common Seal)

Tenderee Common Seal of the Company

Witnesses

Signature: \_\_\_\_\_

Signature: \_\_\_\_\_

Name: \_\_\_\_\_

Name: \_\_\_\_\_

Address: \_\_\_\_\_

Address: \_\_\_\_\_

\_\_\_\_\_

\_\_\_\_\_

\_\_\_\_\_

\_\_\_\_\_

For (name of The Manufacturer / Supplier / Contractor / Agreementor)

Signed by Mr.

(Contract / Agreementor name) in the presence of the following witnesses.

Binding Signature of Contract / Agreementor:

(Authorized Signatory for Affixing Common Seal) Contract / Agreementor Common Seal of the Company

Witnesses

Signature: \_\_\_\_\_

Signature: \_\_\_\_\_

Name: \_\_\_\_\_

Name: \_\_\_\_\_

Address: \_\_\_\_\_

Address: \_\_\_\_\_

\_\_\_\_\_

\_\_\_\_\_

\_\_\_\_\_

\_\_\_\_\_



## Checklist for Eligibility Criteria

Sr No	Eligibility Criteria	Supporting to Eligibility
1	Valid Registration / Empanelment Certificate with any Government / Semi Government Enterprise, Municipalities, Large size reputed private enterprise.	Copy of Registration if any.
2	The Bidders who are not registered with above agencies mentioned in point no 1 but has successfully executed similar or large capacity project can also bid.	PO/WO, Completion certificate of work not older than 2 years.
3	Valid PAN and GST Certificate	Provide Self Certified Copy of Registration with Number
4	The Bidder must have at satisfactory experience in Design, Supply, Construct, Erect, Install And Trial Run Of Main Air Grid Piping System For Air Distribution On Turnkey Basis of Such Capacity or larger than this for Waste Water Treatment - Infrastructure projects work.	Work order and completion certificate with in the last three financial years. Please Provide PO and Completion Certificate for minimum 5 Executed Orders. Out of these, One project should be of such large capacity or higher capacity than this.
5	The bidder should have positive Net worth of last year ending on 31st March 2023.  Minimum Network of Rs 1.00 Crs as per last audited Balance Sheet	The bidder shall submit CA certified audited Balance sheet and Income statement duly signed by the CA and authorized signatory/ies of the bidders  CA Certified Network Certificate.
6	Financial Criteria  Working Capital in excess of 1.0 Crs.  Profit after Tax Should be Positive for last year	Provide CA Certified Copy
7	The Bidder should have qualified & experienced manpower on his payroll. They should have their own/ Designing and manufacturing Facility with qualified team and infrastructure.	Self-certified letter of the list of manpower clearly showing their name, Age, basic qualification, and Experience. Should also share the details regarding their manufacturing facility infrastructure and Designing Facility infrastructure details.
8	The supplier must demonstrate the ability to offer onsite aftersales support in Gujarat, India, including sufficient spares stock facility in the region.	Self-certified letter along details of qualified service team should be attached with offer. Have to provide minimum turnaround time for any service request in self-certified letter.

## Checklist for Document to Submit

Sr No	List of Documents	Submitted Y/N (Pg No)
1	Bid duly signed & sealed (with official seal) in original on all pages with all pages duly numbered. Tender document with corrigendum if any to be signed and stamped on each page and submitted along with technical bid	
2	Registration details: Certificate of Incorporation & MOA for company/ Registered Partnership deed for partnership firm/ Shop & Establishment certificate for proprietorship firm.	
3	List of present Directors/ owners/ executive council members/ trustees/ Board members as applicable with Correspondence address, telephone number, Fax number, email and related details of bidder.	
4	Copy of GST Registration	
5	Legal status (Individual, Proprietary firm, Partnership firm or Limited Company) of the company along with statutory details (Registration No., PAN No., other required valid licenses).	
6	General power of attorney / Board of Directors resolution/ Deed of Authority for Signing Bid Documents, Contract / Agreement/Agreement and for all Correspondences / Documentations thereof.	
7	Income Tax Returns for last three financial years i.e., 2020-21, 2021-22 & 2022-23. CA certified Balance sheet and Income statement duly signed by the statutory auditors and authorized signatory/ies of the Bidder for the Financial years 2020-21, 2021-22 & 2022-23.	
8	Copy of ISO Certification, Licencing certificate of Technical Colaborator if any	
9	Original Chartered Accountant certificate clearly indicating Net-worth and turnover of the bidder in the last three years ending on 31st March 2021. (i.e., for financial year 2020-21, 2021-22 & 2022-23).	
10	Clause by clause compliance statement for the whole Tender Document including all Annexures.	
11	Self-certified letter of list of manpower engages for this project site work.	
12	Self-certified letter for registered office and Address Proof document (Sales dead, rent agreement and last month electricity bill).	
13	PO/WO and Completion Certificate copies for Executed Orders as per Eligibility Criteria.	

1) Letter for EMD submission (On Letter Head duly signed by Authorised Person)

To  
CEO  
Narol Textile Infrastructure & Enviro Management  
ATPA Earth, RS no 170 Part, Opp Balaji Petrol Pump.  
Piplaj Pirana Road, Piplaj, Narol Ahmedabad 382405

Sub: Earnest Money Deposit Against Tender Ref No: **NTIEM/130MLD/Dec/004-2023.**

Dear Sir,

With reference to above and as per terms and conditions of tender we are sending Herewith

D.D. / Pay Order No: \_\_\_\_\_ Dated \_\_\_\_\_ drawn on

\_\_\_\_\_ Payable at Ahmedabad

for Rs. \_\_\_\_\_ (In words \_\_\_\_\_)

\_\_\_\_\_ only) being the amount of E.M.D.

Kindly acknowledge the stamped receipt.

Thanking You

Yours Faithfully

For,

Name of Authorised Person:

Designation:

Date:

Place:

2) Letter for Tender Fees submission (On Letter Head duly signed by Authorised Person)

To  
CEO  
Narol Textile Infrastructure & Enviro Management  
ATPA Earth, RS no 170 Part, Opp Balaji Petrol Pump.  
Piplaj Pirana Road, Piplaj, Narol Ahmedabad 382405

Sub: Tender Fees Submission Against Tender Ref No: NTIEM/130MLD/Dec/004-2023

Dear Sir,

With reference to above and as per terms and conditions of tender we are sending Herewith

D.D. / Pay Order No: \_\_\_\_\_ Dated \_\_\_\_\_ drawn on

\_\_\_\_\_ Payable at Ahmedabad

for Rs. \_\_\_\_\_ (In words \_\_\_\_\_)

---

only) being the amount of Tender Fees.

Kindly acknowledge the stamped receipt.

Thanking You

Yours Faithfully

For,

Name of Authorised Person:

Designation:

Date:

Place:

3) Declaration – Black Listed (On Letter Head duly signed by Authorised Person)

To  
CEO  
Narol Textile Infrastructure & Enviro Management  
ATPA Earth, RS no 170 Part, Opp Balaji Petrol Pump.  
Piplaj Pirana Road, Piplaj, Narol Ahmedabad 382405

Sub: Declaration

Ref: Tender Ref No: **NTIEM/130MLD/Dec/004-2023**

Dear Sir,

I / We have carefully gone through and clearly understood the tender notice, tender terms and conditions and tendered to execute and satisfactorily complete the whole work strictly in accordance with the said Tender.

I/We hereby solemnly declare that none of Our Partners / Directors Jointly or Severally or Our Firm / Company / Associates Company, Subsidiary Company / SPV have not been Black Listed by the Central Government or any State Government or It's Undertaking.

I/We hereby further declare that, if the above Declaration is found untrue, Narol Textile Infrastructure & Enviro Management shall be entitled to take any action against us severally and or individually or our firm / Company, in this regard in any manner that may deem fit by Narol Textile Infrastructure & Enviro Management

Thanking You

Yours Faithfully

For,

Name of Authorised Person:

Designation:

Date:

Place:

4) Declaration – Undertaking (On Letter Head duly signed by Authorised Person)

To,  
CEO  
Narol Textile Infrastructure & Enviro Management  
ATPA Earth, RS no 170 Part, Opp Balaji Petrol Pump.  
Piplaj Pirana Road, Piplaj, Narol Ahmedabad 382405

Sub: Declaration

Ref: Tender Ref No: **NTIEM/130MLD/Dec/004-2023**

Dear Sir,

I/we have visited the site, understood the site condition along with understanding the purpose of Design, Supply, Construct, Erect, Install And Trial Run Of Main Air Grid Piping System For Air Distribution On Turnkey Basis and its application, Tender notice, details to be furnished along with technical bid, plans, specifications and conditions of Contract / Agreement for the above-mentioned work, do hereby Tender to execute and complete the whole work strictly in accordance with the said plans and specifications and conditions of Contract / Agreement at the rates set out in the priced schedule and quantities attached hereto.

I assert with confidence that my/our proposed bid is the best suited solution for the said purpose.

I/we agree to finish the whole work as per instructions within mentioned time limit from the date of issue of Letter of Intent or actual commencement of the work whichever is earlier.

I/We have deposited EMD as per specified in tender document by D.D./PO along with the technical bid in your office which amount is not to bear any interest and I / We do hereby agree that this sum shall be liable to be forfeited by the Narol Textile Infrastructure & Enviro Management at its sole discretion, in the event of your accepting my /our Tender and my/our failing to execute the Contract / Agreement when called upon to do so.

It is understood by me /us that the lowest or any Tender will not necessarily be accepted and that no reason shall be given for such non acceptance.

I/We agree to keep our offer valid for 180 days or for a further period as would be desired by the Narol Textile Infrastructure & Enviro Management, from the date of the opening of the Price bid. We agree to all the terms and conditions of the technical bid.

Thanking You  
Yours Faithfully

For,

Name of Authorised Person:

Designation:

Date:

Place:

5) Deviation Letter (On Letter Head duly signed by Authorised Person)

To,  
CEO  
Narol Textile Infrastructure & Enviro Management  
ATPA Earth, RS no 170 Part, Opp Balaji Petrol Pump.  
Piplaj Pirana Road, Piplaj, Narol Ahmedabad 382405

Sub: Deviation details

Ref: Tender Ref No: **NTIEM/130MLD/Dec/004-2023.**

Dear Sir,

List of all Deviation with complete details. Any commercial deviation will not be accepted by NTIEM,

- 1) Technical Deviation List (Point No with Page Number)
- 2) Commercial Deviation List (Point No with Page Number)

Thanking You

Yours Faithfully

For,

Name of Authorised Person:

Designation:

Date:

Place:

Note:

If the Schedule is not submitted duly filled in, the bid will be considered as incomplete. (In case of "NO DEVIATION" the Schedule be submitted mentioning "NO DEVIATION"). If nothing is mentioned then it will be considered That bidders have "no deviation"

6) Trader Authorization Letter (On Letter Head duly signed by Authorised Person)

To,  
CEO  
Narol Textile Infrastructure & Enviro Management  
ATPA Earth, RS no 170 Part, Opp Balaji Petrol Pump.  
Piplaj Pirana Road, Piplaj, Narol Ahmedabad 382405

Sub: Trader Authorization Letter

Ref: Tender Ref No: **NTIEM/130MLD/Dec/004-2023**

Dear Sir,

M/s \_\_\_\_\_ is authorised OEM (Original Equipment Manufacturer) associated for selling and servicing of our equipments manufactured by M/s \_\_\_\_\_

We authorize M/s \_\_\_\_\_ to participate in Narol Textile Infrastructure & Enviro Management Tender Number **NTIEM/130MLD/Dec/004-2023** with our experience in Design, Supply, Construct, Erect, Install And Trial Run Of Main Air Grid Piping System For Air Distribution ON TURNKEY BASIS.

We assure you that in case of bid selected, we will execute job of Design, Supply, Construct, Erect, Install And Trial Run Of Main Air Grid Piping System For Air Distribution On Turnkey Basis Under capacity Upgradation Project from 100 MLD to 130 MLD facility for textile CETP at Gyaspur, Ahmedabad. project execution

We also provide you the necessary spares, technical and onsite support during the warranty period or minimum 5 years whichever is more.

We look forward for long fruitful and mutually beneficial relationship with you in years to come.

Thanking you.

For,

Authorised Signatory

Date:

Place:



7) Format for Advance Bank Guarantee

Bank Guarantee No.:----- Dated: -----

To,  
CEO  
Narol Textile Infrastructure & Enviro Management  
ATPA Earth, RS no 170 Part, Opp Balaji Petrol Pump.  
Piplaj Pirana Road, Piplaj, Narol Ahmedabad 382405

Sub: Advance Bank Guarantee

Ref: Tender Ref No: **NTIEM/130MLD/Dec/004-2023**

Advance Bank Guarantee Amount: \_\_\_\_\_ Tender Award Date: \_\_\_\_\_

This deed of Guarantee made this day of ----- between ----- (name of bank) having registered office at ----- and branch office at ----- (hereinafter referred to as "Bank") of the one part and Narol Textile Infrastructure & Enviro Management, ATPA Earth, RS no 170 Part, Opp Balaji Petrol Pump. Piplaj Pirana Road, Piplaj, Narol Ahmedabad 382405 (hereinafter called the NTIEM) of the other part.

Whereas Narol Textile Infrastructure & Enviro Management has awarded the tender No. **NTIEM/130MLD/Dec/004-2023** for Design, Supply, Construct, Erect, Install And Trial Run Of Main Air Grid Piping System For Air Distribution On Turnkey Basis Under capacity Upgradation Project from 100 MLD to 130 MLD facility for textile CETP at Gyaspur, Ahmedabad. (Hereinafter called "the Contract") To M/s ----- its registered office at ----- (hereinafter called "the Manufacturer / Supplier / Contractor / Contractor").

Whereas the Manufacturer / Supplier / Contractor is bound by the said Contract to submit to the NTIEM an irrevocable Advane Guarantee bond for a total amount of Rs ----- (Rs. in words).

Now, we the undersigned (Name of Bank official), of the bank being fully authorized to sign and to incur obligations for and on behalf of the Bank hereby declare that the said Bank will guarantee the NTIEM the full amount of Rs. ----- (Rs. in words) as stated above.

After the Manufacturer / Supplier / Contractor has signed the aforesaid contract with the NTIEM, the Bank further agree and promise to pay the amount due and payable under this guarantee without any demure merely on a demand from the NTIEM stating that the amount claimed is due by way of loss or damage cause to or would be caused or suffered by the NTIEM by reason of any breach by the said Manufacturer / Supplier / Contractor of any of the terms or conditions contained in the said agreement or by reason of the Manufacturer / Supplier / Contractor failure to perform the said agreement. Any such demand made on the Bank shall be conclusive as regards the amount due and payable by the Bank under this guarantee. However, our liability under this guarantee shall be restricted to an amount not exceeding Rs. ----- (in words) only.

We ----- (indicate the name of Bank), further undertake to pay to the NTIEM any money so demanded notwithstanding any dispute or dispute raised by the Manufacturer / Supplier / Contractor in any suit or proceeding pending before any court or Tribunal relating to liability under this present being absolute and unequivocal. The payment so made by us (name of Bank) under this bond shall be a valid discharge of our liability for payment there under and the Manufacturer / Supplier / Contractor shall have no claim against us for making such payment.

We ----- (indicate the name of bank), to further agree that the guarantee herein contained shall remain in full force and effect during the period that would be taken for the performance of the said agreement and that it shall continue to be enforceable till all the dues of the NTIEM under or by virtue of the said agreement have been fully paid and its claims satisfied or

discharged by ----- (Designation & address of contract signing authority) on behalf of NTIEM certify that the terms and conditions of the said agreement have been fully and properly carried out by the said Manufacturer / Supplier / Contractor and accordingly discharges this guarantee.

Notwithstanding anything to the contrary contained herein the liability of the bank under this guarantee will remain in force and effect until such time as this guarantee is discharged in writing by the NTIEM or until (date of validity/extended validity) whichever is earlier and no claim shall be valid under the guarantee unless notice in writing thereof is given by the NTIEM within validity/extended validity period of guarantee from the date of aforesaid.

Provided always that we .....(name of bank) unconditionally undertakes to renew this guarantee or to extend the period of guarantee form year to year before the expiry of the period or the extended period of guarantee, as the case may be on being called upon to do so by the NTIEM. If the guarantee is not renewed or the period extended on demand, we.....(name of bank) shall pay the NTIEM the full amount of the guarantee on demand without demur.

We ..... (indicate the name of Bank), to further agree with the NTIEM that the NTIEM shall have the fullest liberty without our consent and without effecting in any manner out of obligation hereunder to vary any of the terms and conditions of the said contract from time to time or to postpone for any time or from time to time any to power exercisable by the NTIEM against the said Manufacturer / Supplier / Contractor and to forbear or enforce any of the terms and conditions of the said agreement and we shall not be relieved from our liabilities by reason of such variation, or extension being granted to the said Manufacturer / Supplier / Contractor for any bearance act or omission on the part of the NTIEM or any indulgence by the NTIEM to the said Manufacturer / Supplier / Contractor or by any such matter or thing whatsoever which under the law relating to sureties for the said reservation would relieve us from the liability.

The Guarantee hereinbefore contained shall not be affected by any change in the constitution of Bank or of the Manufacturer / Supplier / Contractor / Contractor.

The expressions “the NTIEM”, “the Bank” and “the Manufacturer / Supplier / Contractor / Contractor” hereinbefore used shall include their respective successors and assigns.

We ..... (name of the bank) lastly undertake not to revoke this guarantee during its currency except with the previous consent of the NTIEM in writing.

Notwithstanding anything to the contrary contained hereinbefore:  
Our liability under this Bank Guarantee shall not exceed and restricted to Rs. .... (in words).

This Bank Guarantee shall be valid up to ....., unless extended on demand by NTIEM.  
The Bank is liable to pay the guaranteed amount or any part thereof under this Bank Guarantee only if NTIEM serve a written claim or demand on or before .....

IN WITNESS WHEREOF we of the Bank have signed and stamped this guarantee on this day of ..... being herewith duly authorized.

Bank Seal  
Name: .....  
Designation:  
Address:

Signature of Bank Authorize Official with seal

8) Non-Disclosure Agreement (Duly signed by Authorised Person from both parties)

## CONFIDENTIALITY AGREEMENT

AN AGREEMENT (the "Agreement") made on \_\_\_\_\_ between Narol Textile Infrastructure & Enviro Management having its registered office at ATPA Earth, RS no 170 Part, Opp Balaji Petrol Pump, Piplaj Pirana Road, Piplaj, Narol Ahmedabad 382405 ("NTIEM") and Its plant located at Part 34, Nr Animal Health Foundation, Gyaspur, Narol, Ahmedabad and \_\_\_\_\_ having their registered office at \_\_\_\_\_ ("Successful Bidder"). NTIEM and Successful Bidder are collectively the "Parties" and each, a "Party".

### Background

- NTIEM owns and/or holds certain confidential information in the form of inventions, processes, techniques, methods of treatment, know-how, formulas, ideas, drawings, modules, plans, designs, products, samples, specifications, trade secrets, processing data, Operational data and other information and/or material relating to NTIEM CETP capacity upgradation project from 100 to 130 MLD and associated activity , together with any modifications, variations and/or improvements thereto, (collectively "NTIEM Information") and has agreed to disclose certain NTIEM Information to Successful Bidder subject to the terms of this Tender document and Contract / Agreement.
- Successful Bidder owns and/or holds certain confidential information in the form of inventions, processes, techniques, methods of production, know-how, formulas, ideas, drawings, modules, plans, designs, products, samples, specifications, trade secrets, processing data, Operational data and other information and/or material relating to Successful Bidder's NTIEM CETP capacity upgradation project from 100 to 130 MLD and associated activity, together with any modifications, variations and/or improvements thereto, (collectively "Successful Bidder Information") and has agreed to disclose certain Successful Bidder Information to NTIEM subject to the terms of this Agreement.
- A Party who is given NTIEM Information or Successful Bidder Information or acquires NTIEM Information or Successful Bidder Information (as the case may be) is a receiving party ("Receiving Party").
- A Party who (directly or through another person on that Party's behalf) gives NTIEM Information or Successful Bidder Information to the other Party or from whom (directly or through another person on that Party's behalf) the other Party acquires NTIEM Information or Successful Bidder Information (as the case may be) is a disclosing party ("Disclosing Party").
- The Parties acknowledge that NTIEM Information and Successful Bidder Information (collectively, "Information") have been and are being respectively developed by NTIEM and Successful Bidder through the expenditure of substantial time, effort and money, that NTIEM Information and Successful Bidder Information are valuable assets of NTIEM and Successful Bidder respectively and that NTIEM Information and Successful Bidder Information must be kept in strict confidence for the exclusive benefit of NTIEM and Successful Bidder respectively. Both Parties wish to preserve the confidentiality of NTIEM Information and Successful Bidder Information, including any subsequent modifications, variations and/or improvements thereto, for the exclusive benefit of NTIEM and Successful Bidder respectively.

THEREFORE in consideration of the reciprocal disclosures of NTIEM Information and Successful Bidder Information and the reciprocal undertakings set out in this Agreement, the Parties agree as follows:

1. For the limited purpose of NTIEM CETP capacity upgradation project from 100 to 130 MLD and associated activity ("Permitted Purpose"):
  - a) NTIEM agrees to disclose certain Information and Successful Bidder agrees to receive and use NTIEM Information on the terms of this Agreement; and

- b) Successful Bidder agrees to disclose certain Information and NTIEM agrees to receive and use Successful Bidder Information on the terms of this Agreement.
2. Following execution of this Agreement by both Parties, Successful Bidder may deliver and/or disclose Successful Bidder Information to NTIEM and NTIEM may deliver and/or disclose NTIEM Information to Successful Bidder in connection with the Permitted Purpose. These disclosures may be made in writing or by oral communication. For the avoidance of doubt, this Agreement does not compel either Party to disclose to the other Party any NTIEM Information or any Successful Bidder Information (as the case may be). Each Party may, in its sole and absolute discretion, determine which NTIEM Information or Successful Bidder Information (as the case may be) to disclose to the other Party.
3. NTIEM acknowledges and agrees that:
  - a) Successful Bidder Information is proprietary, secret, confidential and valuable to Successful Bidder;
  - b) it owes an obligation of confidence to Successful Bidder in relation to Successful Bidder Information;
  - c) as between the Parties, all rights and interests (including all intellectual property) in Successful Bidder Information solely belong to Successful Bidder; and
  - d) it has no rights or interest in Successful Bidder Information other than the right to use it on the terms of this Agreement.
4. NTIEM must hold Successful Bidder Information in trust and confidence for Successful Bidder and must not, directly or indirectly, use it except to the extent necessary for the Permitted Purpose. Successful Bidder Information must be treated by NTIEM with the same standard of care as a prudent business uses with respect to its own confidential or proprietary information.
5. Successful Bidder acknowledges and agrees that:
  - a) NTIEM Information is proprietary, secret, confidential and valuable to NTIEM;
  - b) it owes an obligation of confidence to NTIEM in relation to NTIEM Information;
  - c) as between the Parties, all rights and interests (including all intellectual property) in NTIEM Information solely belong to NTIEM; and
  - d) it has no rights or interest in NTIEM Information other than the right to use it on the terms of this Agreement.
6. Successful Bidder must hold NTIEM Information in trust and confidence for NTIEM and must not, directly or indirectly, use it except to the extent necessary for the Permitted Purpose. NTIEM Information must be treated by Successful Bidder with the same standard of care as a prudent business uses with respect to its own confidential or proprietary information.
7. A Receiving Party subject to this Agreement must:
  - a) be responsible for maintaining the confidentiality of Information and for taking all reasonable measures to prevent unauthorized use, disclosure, or reverse engineering thereof;
  - b) ensure that Information is kept under Receiving Party's effective control and is secure from theft, loss, damage and unauthorized access, use and disclosure;
  - c) promptly take all steps that Disclosing Party may reasonably require in relation to any theft, loss, damage or unauthorised access, use or disclosure of Information;
  - d) disclose Information only to such of its directors, officers, employees, sub-contractors, agents and advisors as is necessary to carry out the Permitted Purpose and then only to the extent required by any such person to perform his or her duties;
  - e) take all reasonable measures at its own expense to enforce the obligations of confidentiality and restrictions on use contained in this Agreement with respect to any of its current and former directors, officers, employees, sub-contractors, agents and advisors who, while a director, officer, employee, sub-contractor, agent or advisor of Receiving Party, had access to Information;

- f) notify Disclosing Party immediately if it becomes aware of any actual, suspected or likely breach or threatened breach of this Agreement by it or its directors, officers, employees, sub-contractors, agents or advisors;
- g) promptly take all steps that Disclosing Party may reasonably require in relation to any actual, suspected or likely breach or threatened breach of this Agreement; and
- h) upon the request of Disclosing Party, at Receiving Party's cost:
  - i. promptly return to Disclosing Party, and cease use of, all originals and copies of documents or other materials (in whatever form) containing, recording or referring to Information delivered to it in accordance with this Agreement and erase or destroy all electronic or other intangible records containing, recording or referring to NTIEM Information or Successful Bidder Information (as the case may be), which are in the possession, power or control of Receiving Party or of any person to whom Receiving Party has given access; and
  - ii. confirm in writing within 7 days of a request to do so that it has complied with the provisions in this Agreement, including the requirements of Section 7(h)(i).
8. The undertakings of Receiving Party do not apply to NTIEM Information or Successful Bidder Information (as the case may be) which:
  - a) is in the public domain in any country as of the date of this Agreement or which later comes into the public domain in any country through no fault of Receiving Party or any of its directors, officers, employees, sub-contractors, agents or advisors;
  - b) Receiving Party can prove it had in its possession in written or physical form prior to the date of this Agreement;
  - c) is or was lawfully disclosed to Receiving Party at any time by a third party who is or was not then under an obligation of confidence in relation to Information to which such third party is bound;
  - d) Receiving Party can prove is or was independently developed by Receiving Party without Receiving Party relying on, referring to or incorporating any of the Information; or
  - e) Receiving Party is required to disclose by law or order of any court or tribunal of competent jurisdiction, or by any government agency, stock exchange, securities council or regulatory body. In the event of any such requirement, Receiving Party must
    - i. promptly notify Disclosing Party,
    - ii. consult with and follow any reasonable directions from Disclosing Party in an attempt to minimize disclosure, and
    - iii. if disclosure cannot be avoided, only disclose to the extent necessary to comply and use reasonable efforts to safeguard the confidentiality of the disclosed Information.
9. A Party must not attempt to circumvent its obligations to the other Party under this Agreement by combining a portion of the other Party's Information with information derived from another source or sources so as to attempt to justify use of the other Party's Information for its own purpose or that of any other person.
10. Except as provided in this Agreement or as otherwise agreed in writing by the Parties, Receiving Party must not reproduce, in whole or in part, any document delivered to Receiving Party by or on behalf of Disclosing Party and containing NTIEM Information or Successful Bidder Information (as the case may be) except in the ordinary course of the Permitted Purpose.
11. No rights or license to NTIEM Information or Successful Bidder Information are granted directly or implicitly by this Agreement.
12. Neither Party makes or gives any representation, assurance or warranty, express or implied, that NTIEM Information or Successful Bidder Information (as applicable), or any part of it, is accurate, complete or reliable. Receiving Party will be solely responsible for making its own judgment and decisions on NTIEM Information or Successful Bidder Information (as applicable). Each Party acknowledges and agrees that neither Party, nor any of its directors, officers, employees, subcontractors, agents or advisors is liable (whether in negligence or

- otherwise) or accepts responsibility for any loss or damage that the other Party or anyone else may suffer or incur as a result of using or relying on or disclosing any NTIEM Information or Successful Bidder Information.
13. Each Party acknowledges that any breach or threatened breach of this Agreement may cause Disclosing Party immediate and irreparable harm for which damages alone may not be an adequate remedy. Each Party agrees that a Disclosing Party under this Agreement may commence proceedings to restrain any breach or threatened breach of this Agreement and any other unauthorised access to, or use of, any Information or to compel specific performance of this Agreement.
  14. 14. Each Party indemnifies and agrees to keep indemnified and hold the other Party harmless from and against, and must pay the other Party on demand, the amount of all loss, damage, liability, costs and expenses, including any legal costs or expenses on a full indemnity basis, incurred in connection with a Party's representations or warranties being or becoming incorrect in any respect or any breach of a Party's obligations under this Agreement. This indemnity survives the expiry or termination of this Agreement. Each Party's rights hereunder are in addition to (and not in substitution of) all other rights and remedies available to that Party at law, in equity, under contract or otherwise.
  15. 15. NTIEM and Successful Bidder shall use received information in compliance with all applicable laws. For NTIEM Information or Successful Bidder Information that is Personal Information (defined hereinafter), Receiving Party must comply with the applicable laws and this Agreement, and must do all that is reasonably needed on its part to enable Disclosing Party to comply with them.
  16. "Personal Information" means any information that relates to a natural person, which, either directly or indirectly, in combination with the other information available or likely to be available with a body corporate, is capable of identifying such person. A Party must not directly or indirectly make a public announcement about or comment on the existence or terms of this Agreement including any discussions between the Parties without the prior written consent of the other Party.
  17. This Agreement must be interpreted and enforced according to the laws of India. The Parties submit to the jurisdiction of the courts of Ahmedabad. This Agreement is binding upon the Parties to this Agreement, their successors and permitted assignees. It may not be amended except by the express written agreement of the Parties to this Agreement.
  18. The termination date for this Agreement shall be the null. If no termination date is specified above in this clause, the rights and obligations under this Agreement are ongoing, and, for greater certainty, the rights of confidentiality and non-use are to continue following completion of any project or undertaking related to the Permitted Purpose. Either Party may terminate this Agreement for any reason by providing 30 days written notice to the other Party. The rights and obligations of confidentiality and non-use shall survive termination of this Agreement for a period of 5 years from termination.
  19. No failure to exercise or delay in exercising any right, remedy or power under this Agreement and no failure to insist on strict compliance with any obligation under this Agreement will constitute a waiver of the right to demand exact compliance with this Agreement.
  20. Where any provision of this Agreement is expressed to be for the benefit of any person other than a Party, such provision is intended to confer a benefit on such person, enforceable at the suit of that person, in terms of the (Indian) Contracts Act, 1872 and/or the (Indian) Specific Relief Act, 1963, but no rights or remedies of a third party that do not exist or are not available apart from the said legislation as amended from time to time, are hereby conferred.
  21. The obligations in this Agreement are considered reasonable and necessary by the Parties for the protection of Disclosing Party's legitimate interests in NTIEM Information or Successful Bidder Information (as the case may be). If any of the obligations are found to be void or voidable but would be valid and enforceable if some part or parts were deleted or amended, they will apply with such modifications as may be necessary to make them valid and enforceable. If such modification is not possible, then the relevant provisions are to be

severed from this Agreement, without affecting the enforceability, legality or validity of any other provision of this Agreement.

22. A Party may only assign, encumber, declare a trust over or otherwise deal with its rights under this Agreement with the prior written consent of the other Party.
23. The terms of this Agreement continue to apply to the Parties (in addition to any permitted assignee) despite any permitted assignment of any rights under this Agreement or the completion or termination of the Permitted Purpose.

IN WITNESS WHEREOF this Agreement has been entered into by Narol Textiles Infrastructure & Enviro Management and Successful Bidder.

EXECUTED by  
Narol Textile Infrastructure & Enviro Management

Signature of Authorised Signatory  
Name  
Designation

EXECUTED by  
<Name of Successful Bidder>

Signature of Authorised Signatory  
Name  
Designation

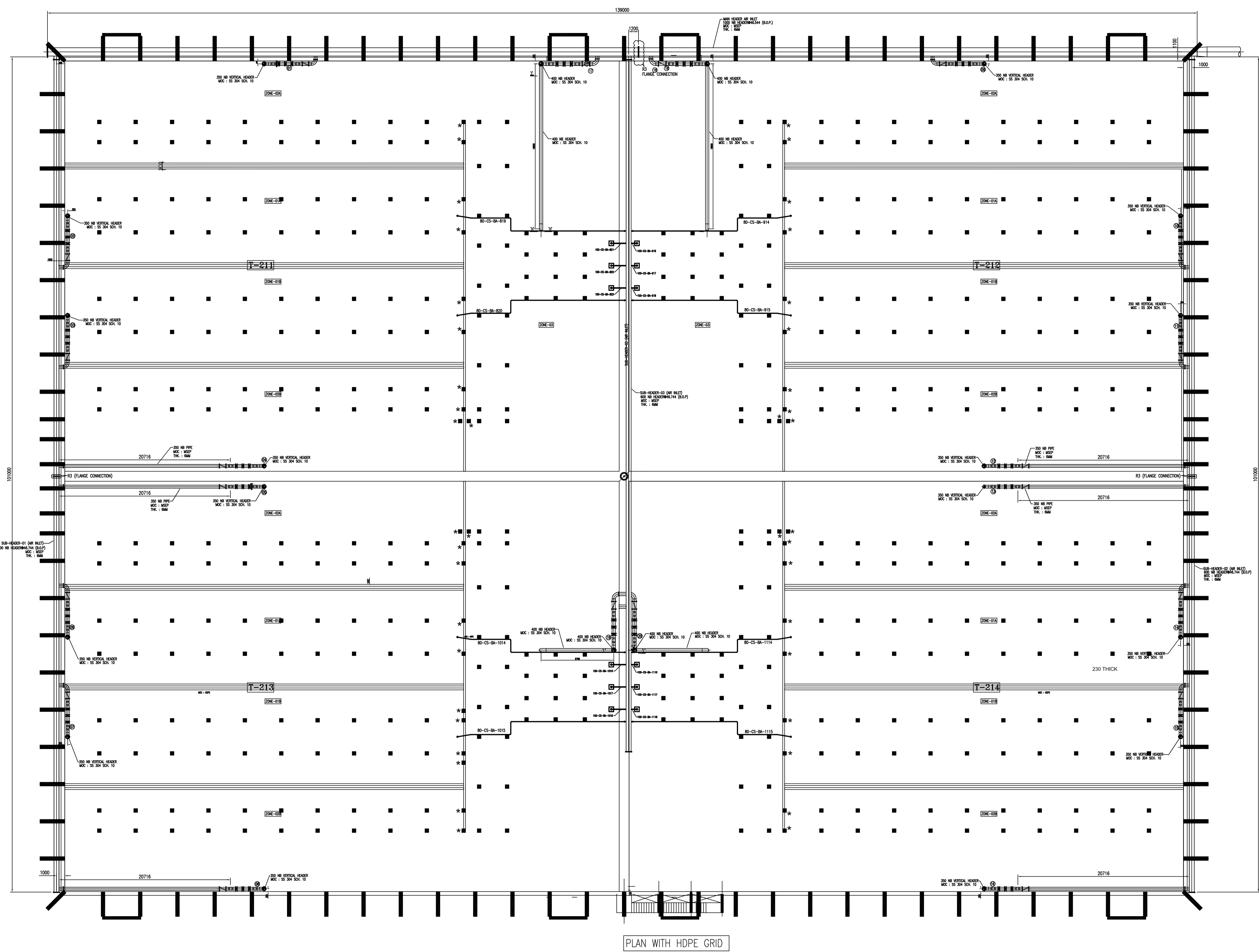
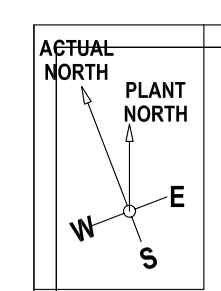

PLAN WITH HDPE GRID

PLAN WITHOUT HDPE GRID (FOR INFORMATION ONLY)

READY FOR FABRICATION

NOTES:  
01) ALL DIMENSIONS ARE IN MM AND LEVELS ARE IN METERS

REVISIONS :

NO.	DATE	DESCRIPTION
R0	24-04-2014	---
R1	09-12-2014	READY FOR CONSTRUCTION
R2	30/07/2015	READY FOR CONSTRUCTION (REV. MARKED IN DRAWING)

OWNER : NAROL TEXTILE INFRASTRUCTURE & ENVIRO MANAGEMENT

PRINCIPAL EPC AGENCY :  
**ADVENT ENVIRO CARE**  
 TECHNOLOGY PVT. LTD.  
 (AHMEDABAD)

PROJ NO : --	PROJ TITLE : <b>COMMON EFFLUENT TREATMENT PLANT</b>
DRG NO : --	DRG TITLE : <b>CFICASS AIR GRID (SHEET NO. : 01 OF 11)</b>
DRAWN : VP	CHECKED : RS
SCALE : --	DATE : 24-04-14



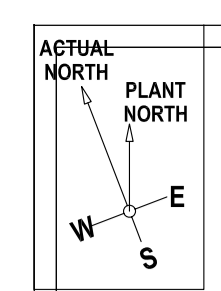

N=843.597  
E=669.472

N=843.5  
E=804.7

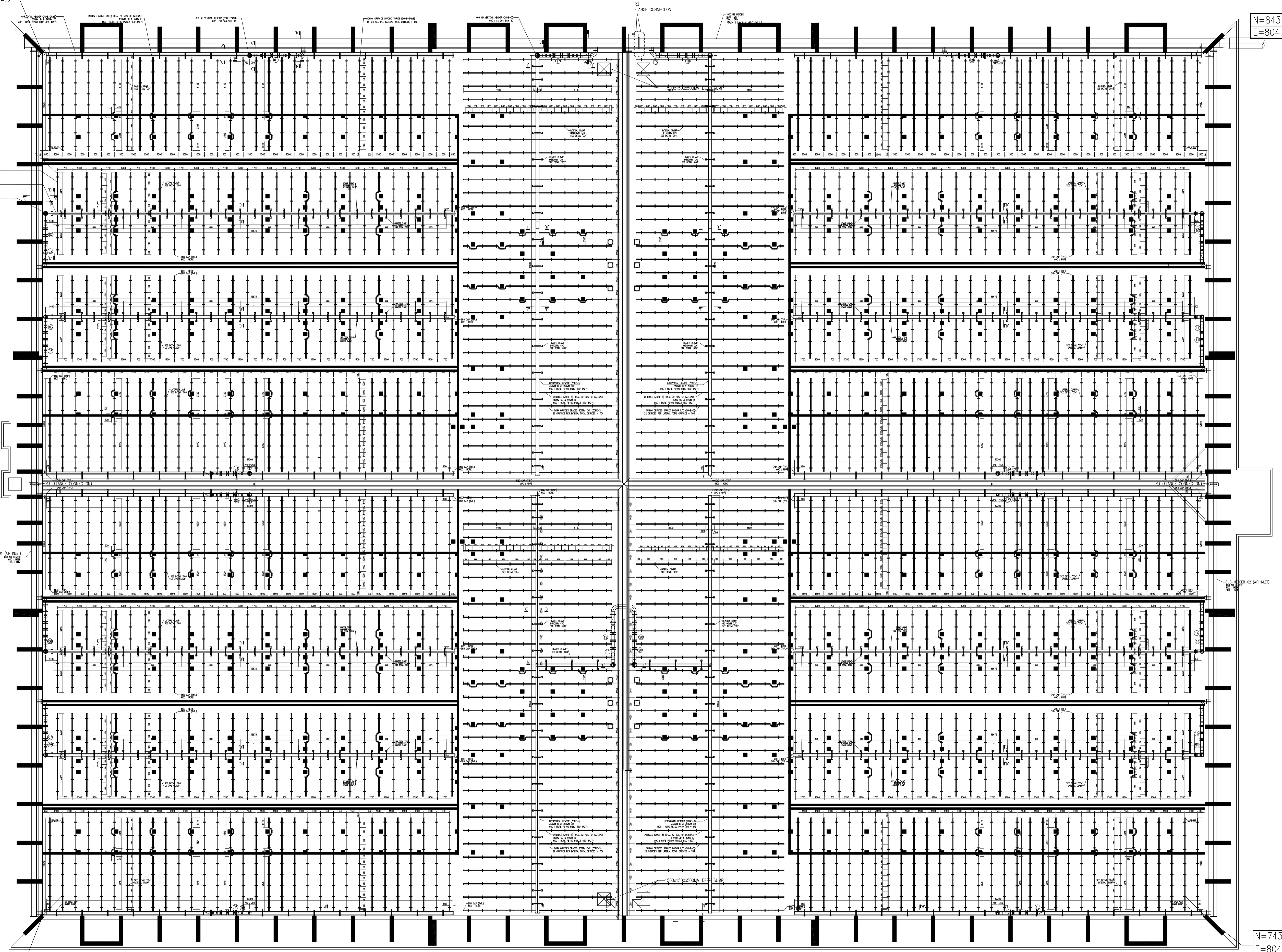

N=743.147  
E=669.472

N=743.1  
E=804.7

PLAN WITH HDPE GRID

READY FOR FABRICATION

NOTES:  
01) ALL DIMENSIONS ARE IN MM AND LEVELS ARE IN METERS

REVISIONS :

NO.	DATE	DESCRIPTION
R0	24-04-2014	---
R1	09-12-2014	READY FOR CONSTRUCTION

OWNER: NAROL TEXTILE INFRASTRUCTURE & ENVIRO MANAGEMENT

PRINCIPAL EPC AGENCY :  
**ADVENT ENVIRO CARE**  
TECHNOLOGY PVT. LTD.  
(AHMEDABAD)

PROJ NO : ---  
PROJ TITLE : **COMMON EFFLUENT TREATMENT PLANT**

DRG NO : ---  
DRG TITLE : **CFICASS AIR GRID**  
(SHEET NO. : 02 OF 11)

DRAWN : VP	CHECKED : RS	SCALE : ---	DATE : 24-04-14
---------------	-----------------	----------------	--------------------

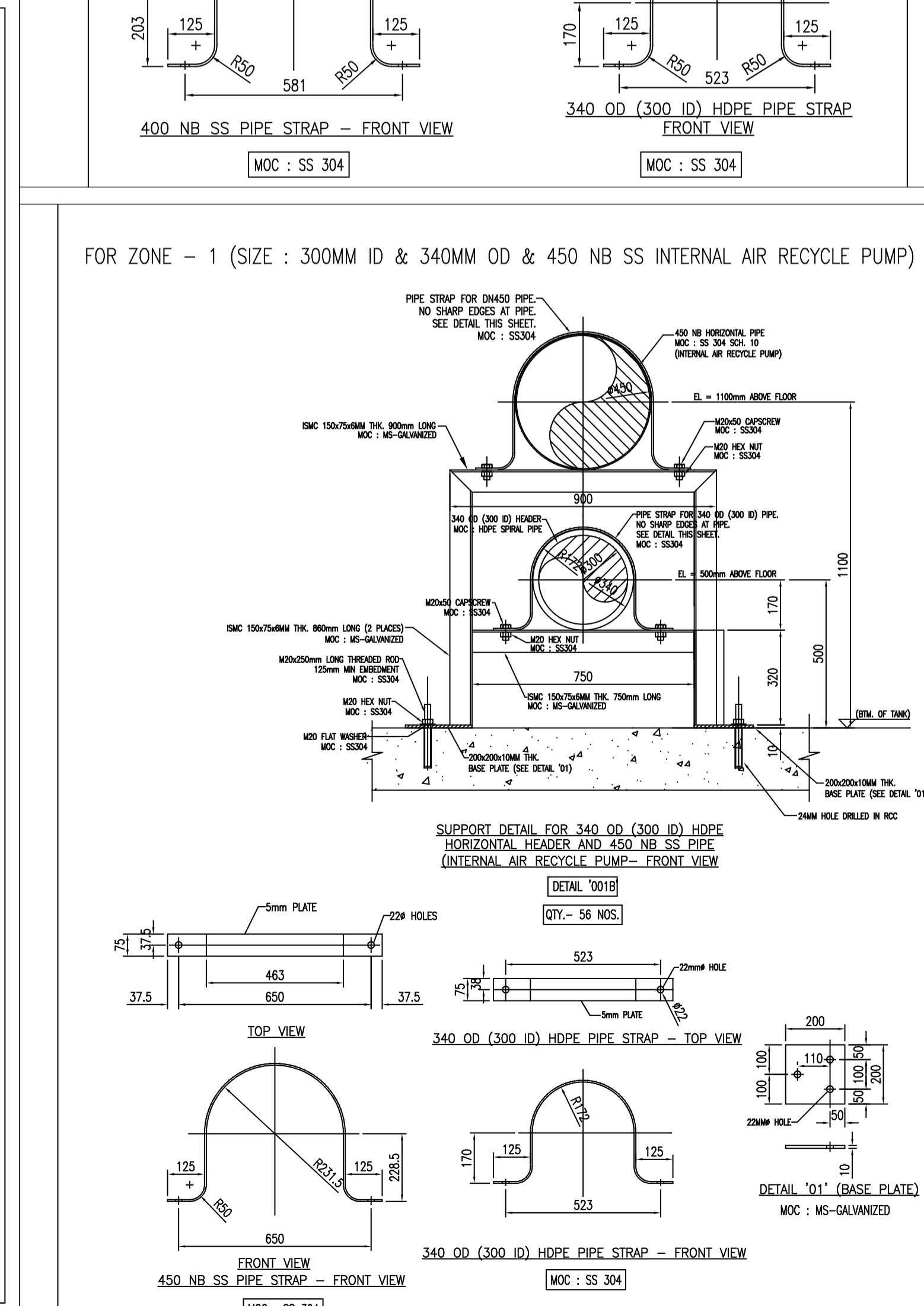
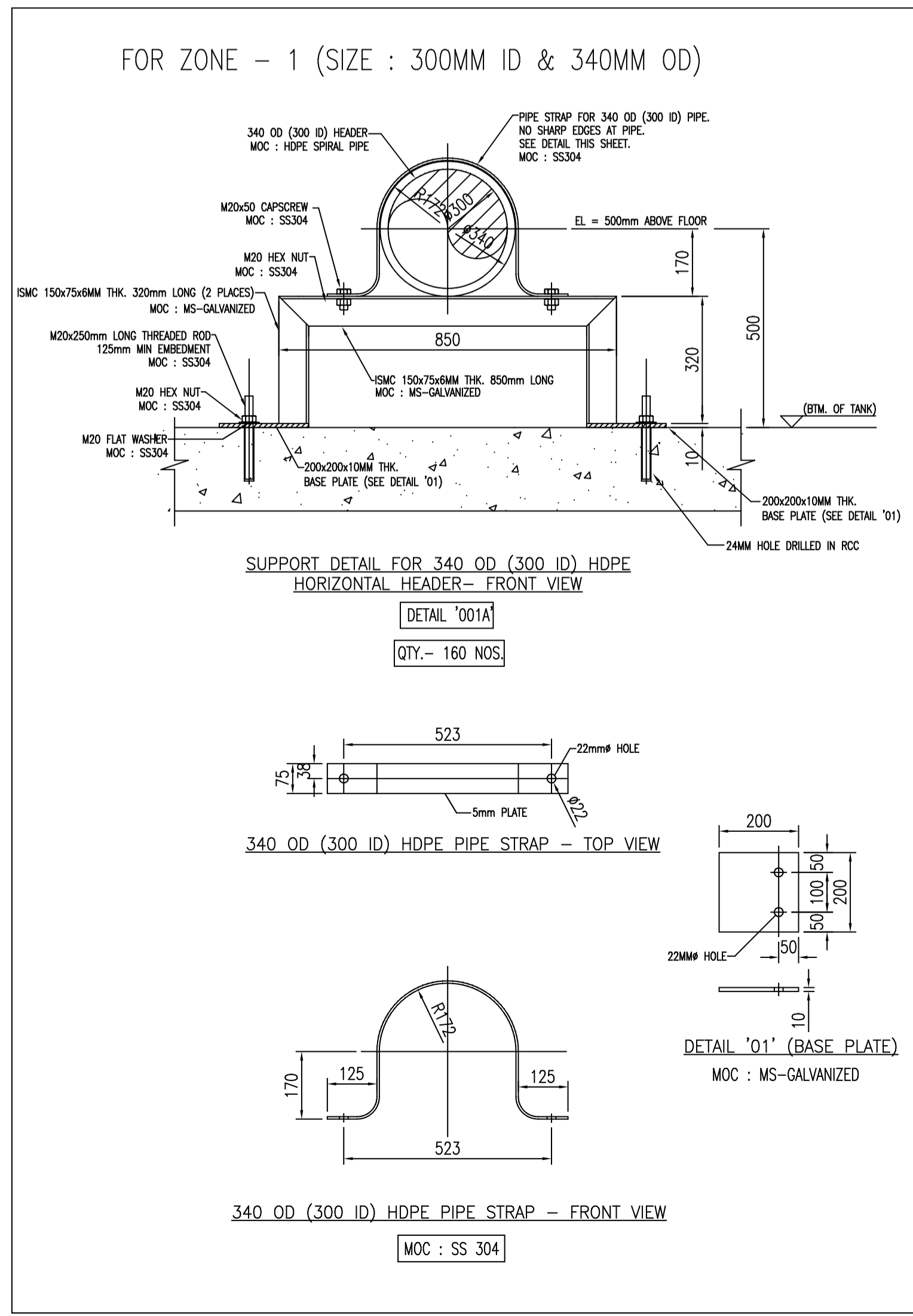
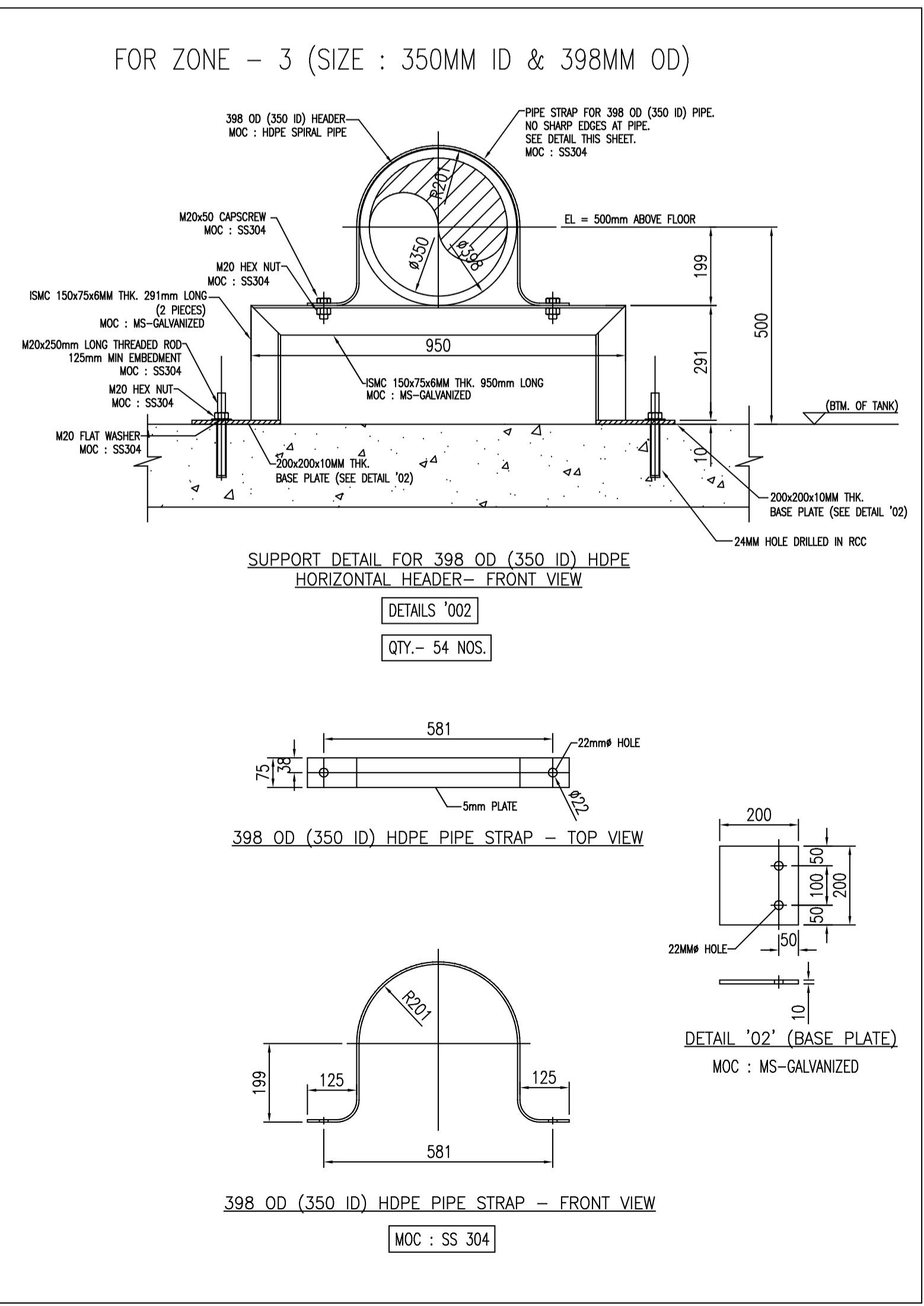
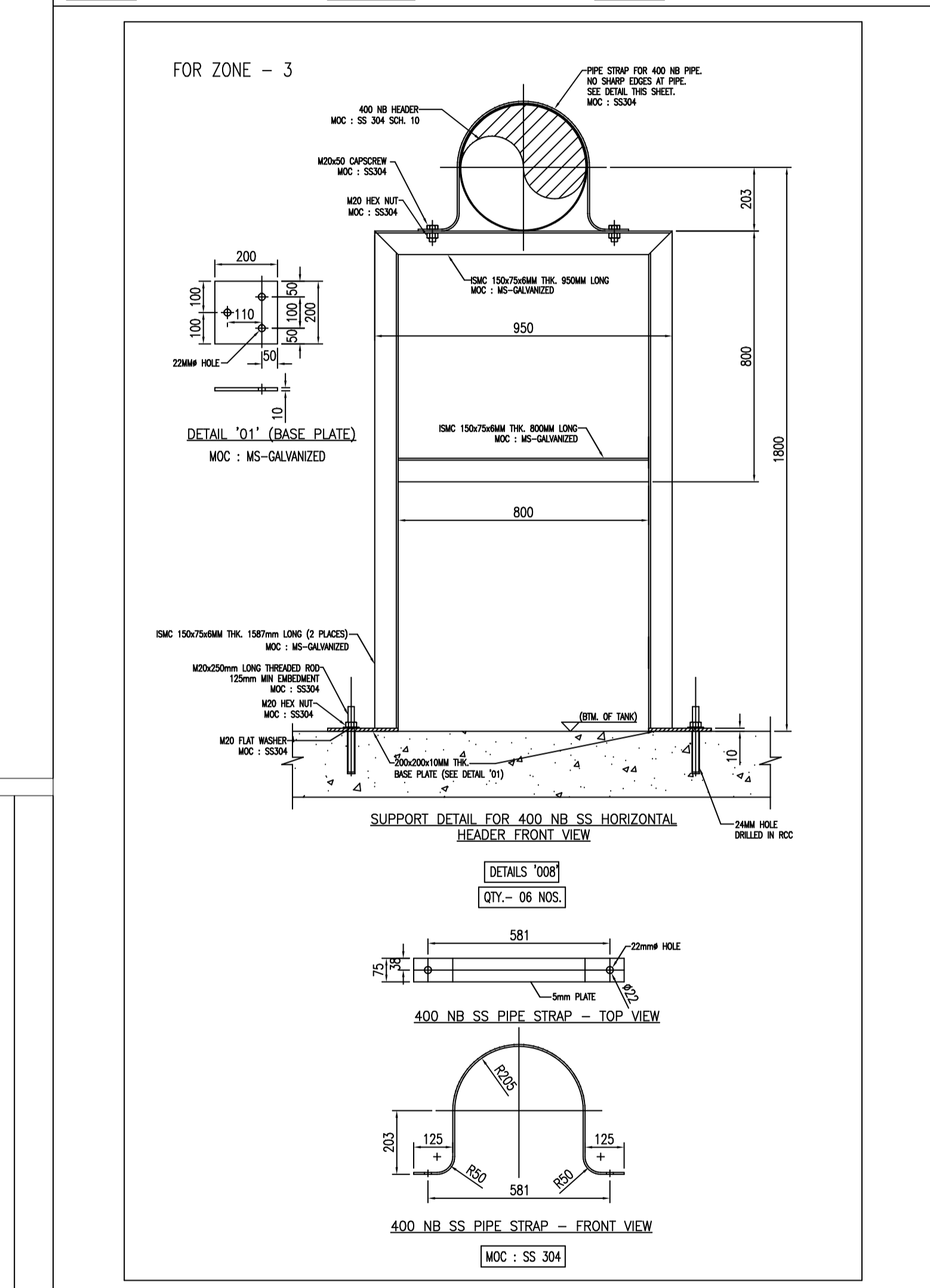
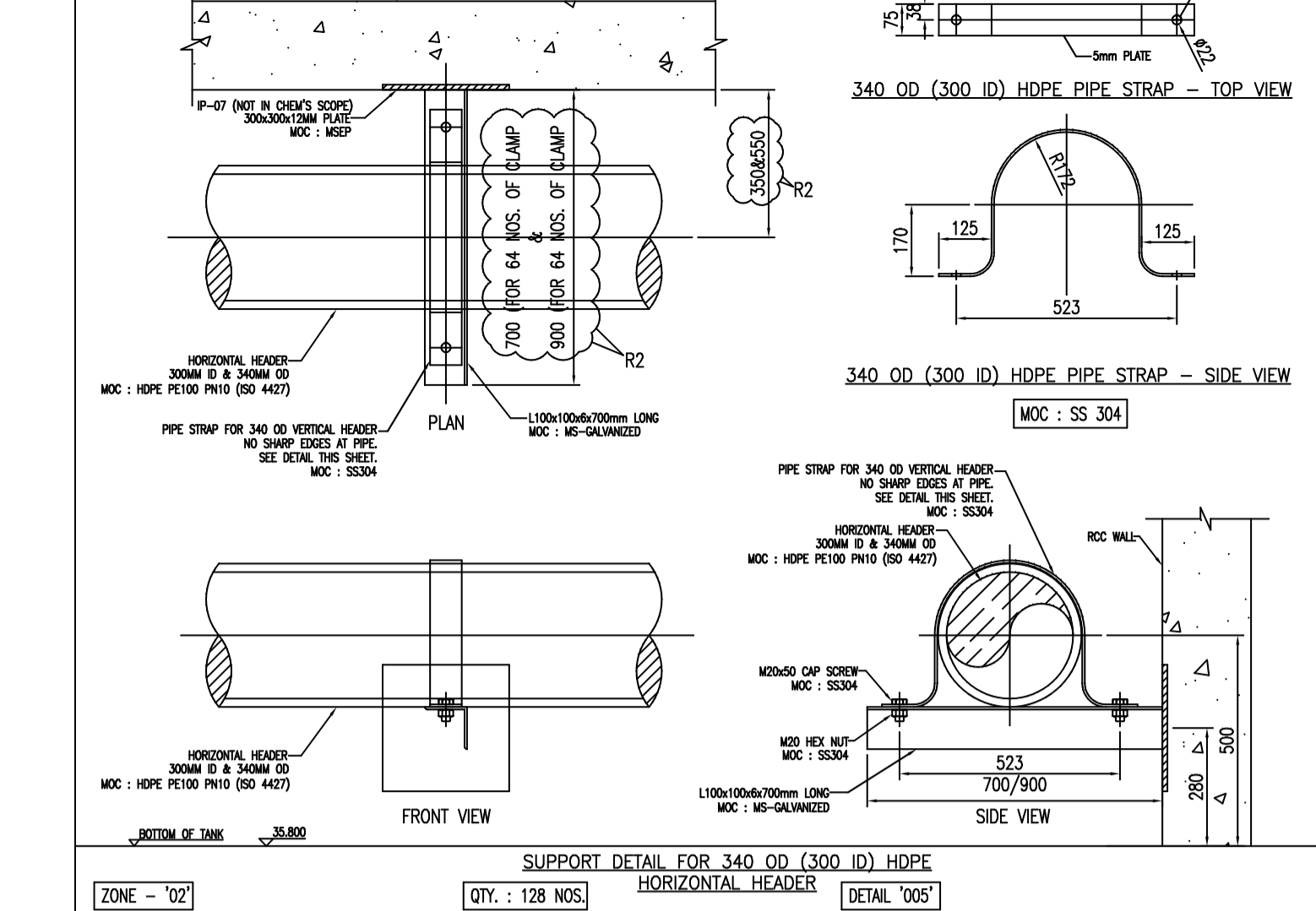
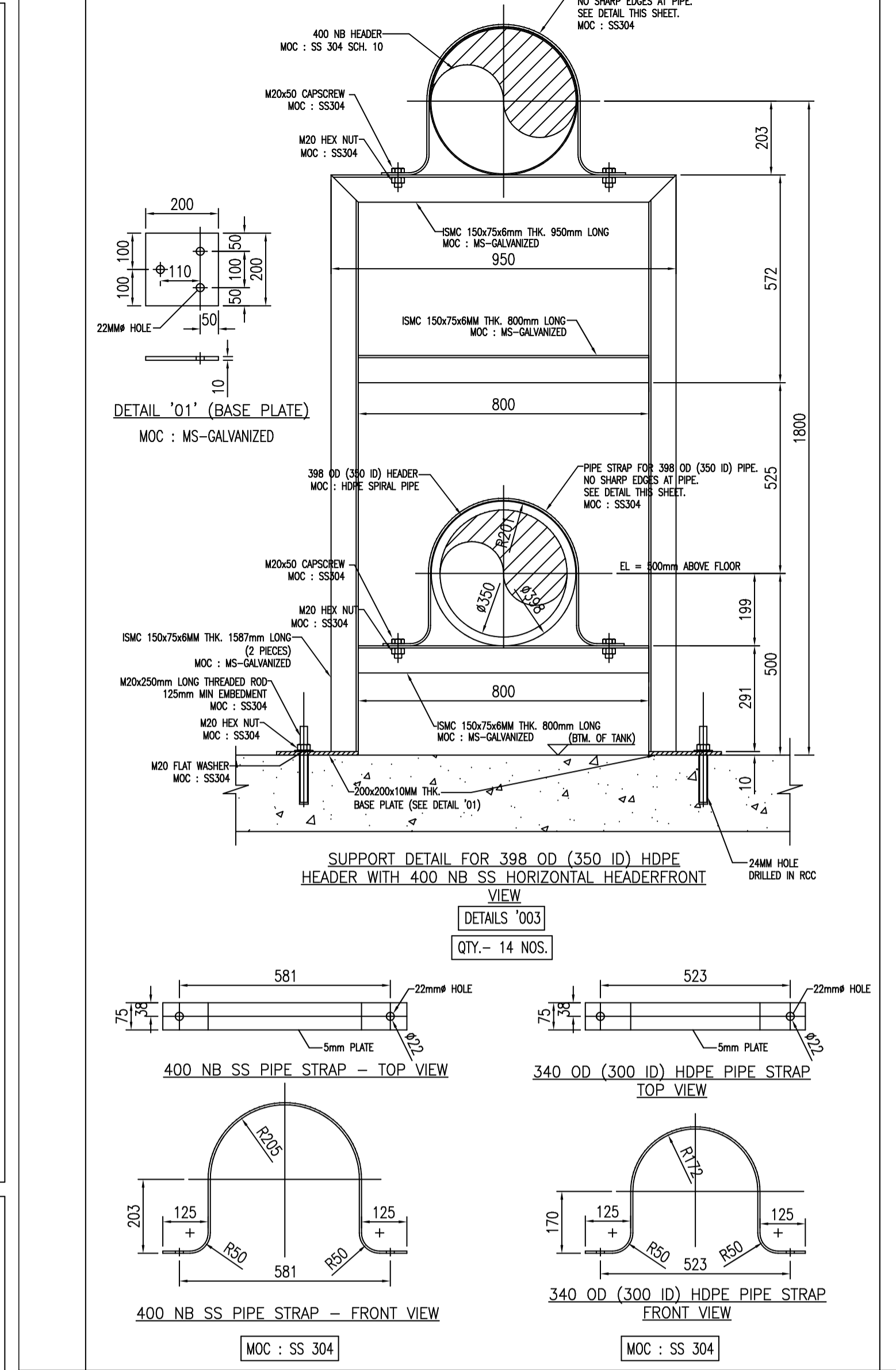
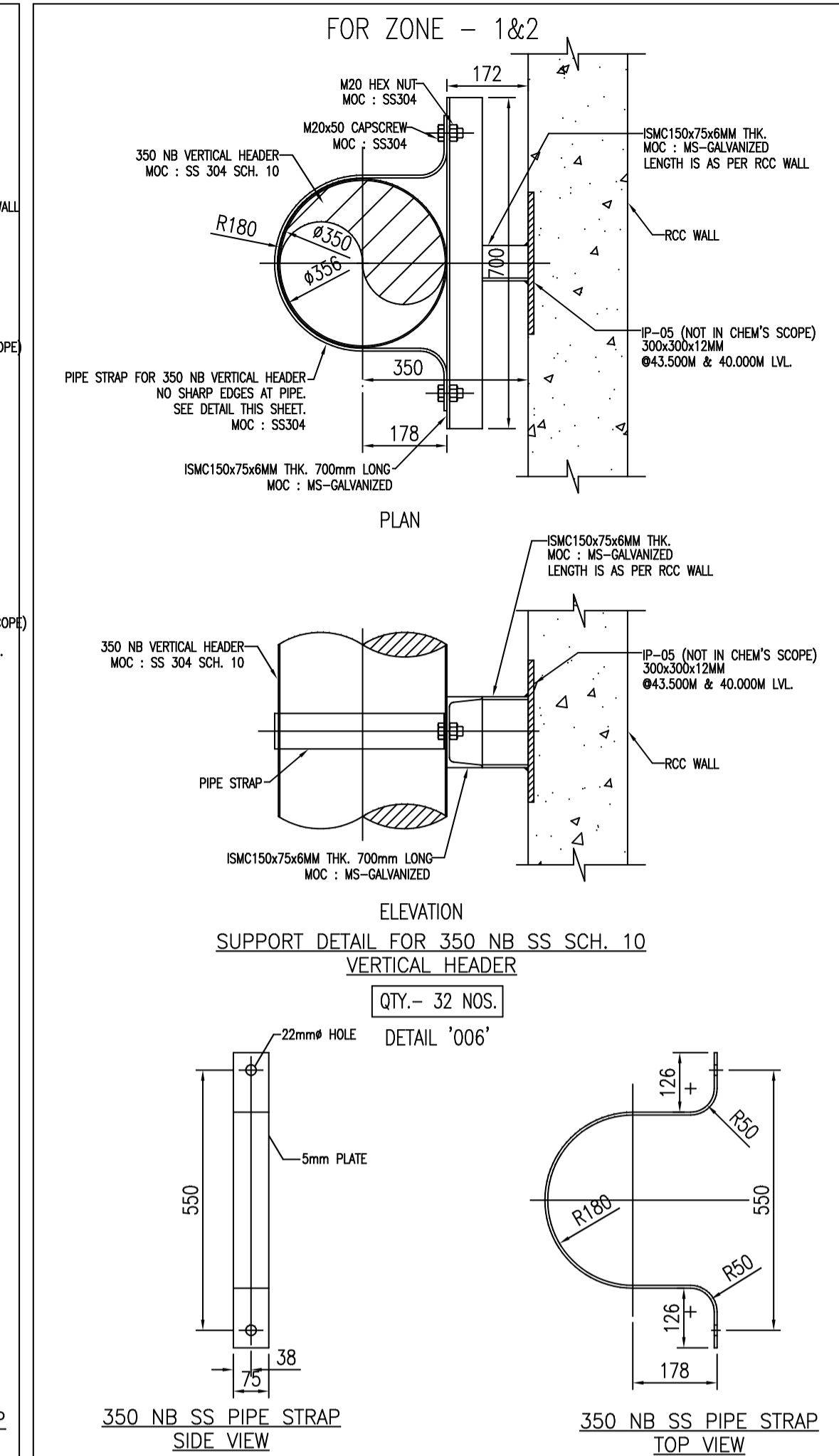
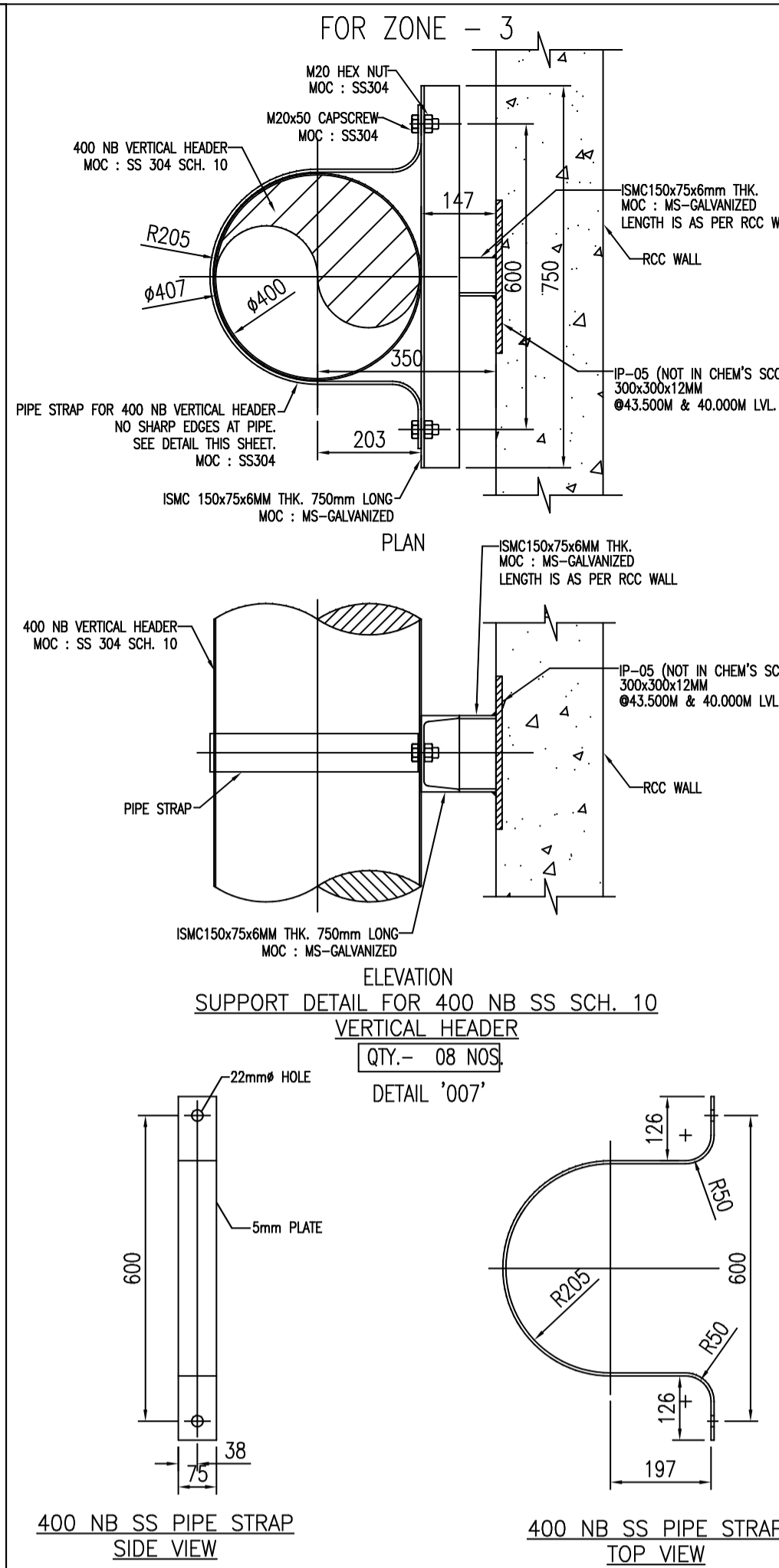
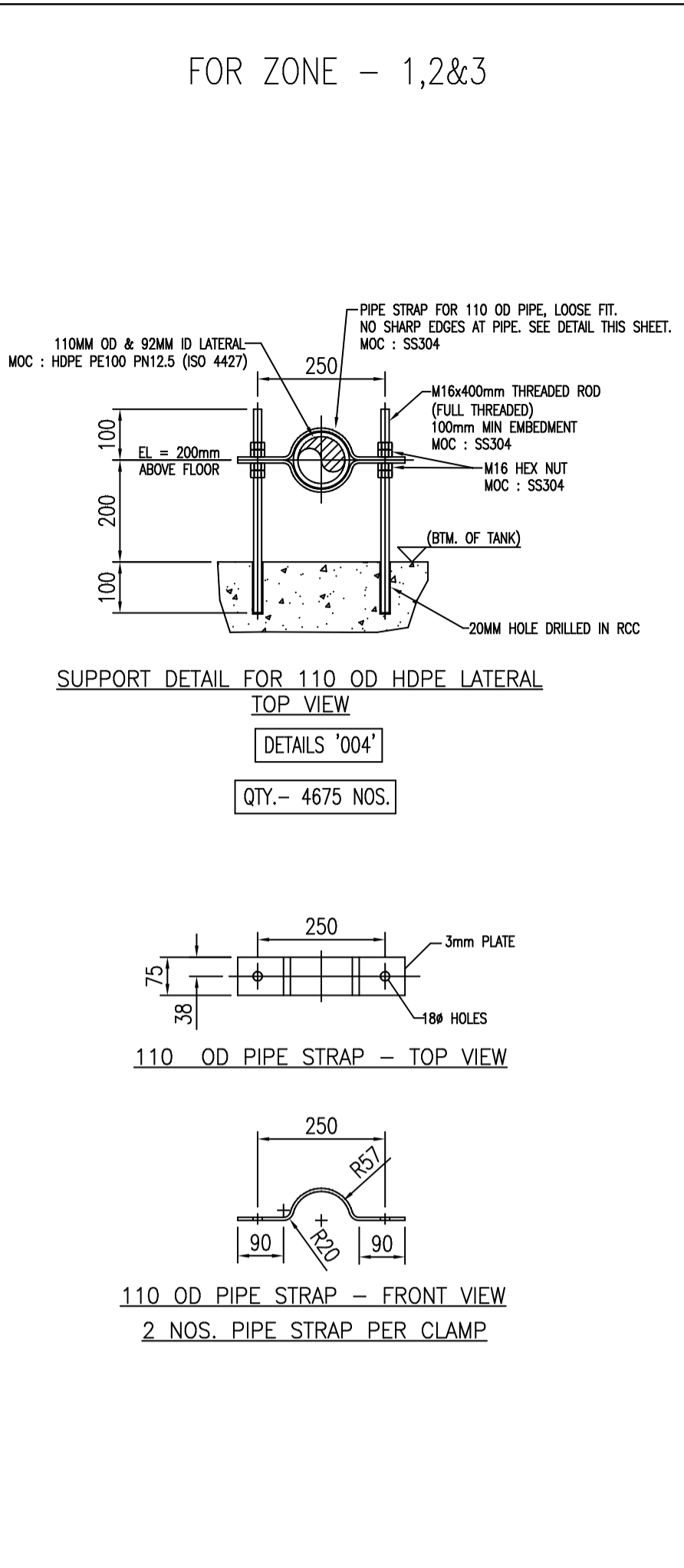

READY FOR FABRICATION

CFICASS AIR GRID CLAMPS

NOTES:  
01) ALL DIMENSIONS ARE IN MM AND LEVELS ARE IN METERS

REVISIONS :

NO.	DATE	DESCRIPTION
RO	24-04-2014	----
R1	09-12-2014	READY FOR FABRICATION
R2	30-07-2015	READY FOR FABRICATION (REV. MARKED IN DRAWING)

OWNER : **NAROL TEXTILE INFRASTRUCTURE & ENVIRO MANAGEMENT**

PRINCIPAL EPC AGENCY : **ADVENT ENVIRO CARE TECHNOLOGY PVT. LTD. (AHMEDABAD)**

PROJ NO : --- PROJ TITLE : **COMMON EFFLUENT TREATMENT PLANT**

DRG NO : --- DRG TITLE : **CFICASS AIR GRID (SHEET NO. : 07 OF 11)**

DRAWN : VP CHECKED : RS SCALE : --- DATE : 24-04-14

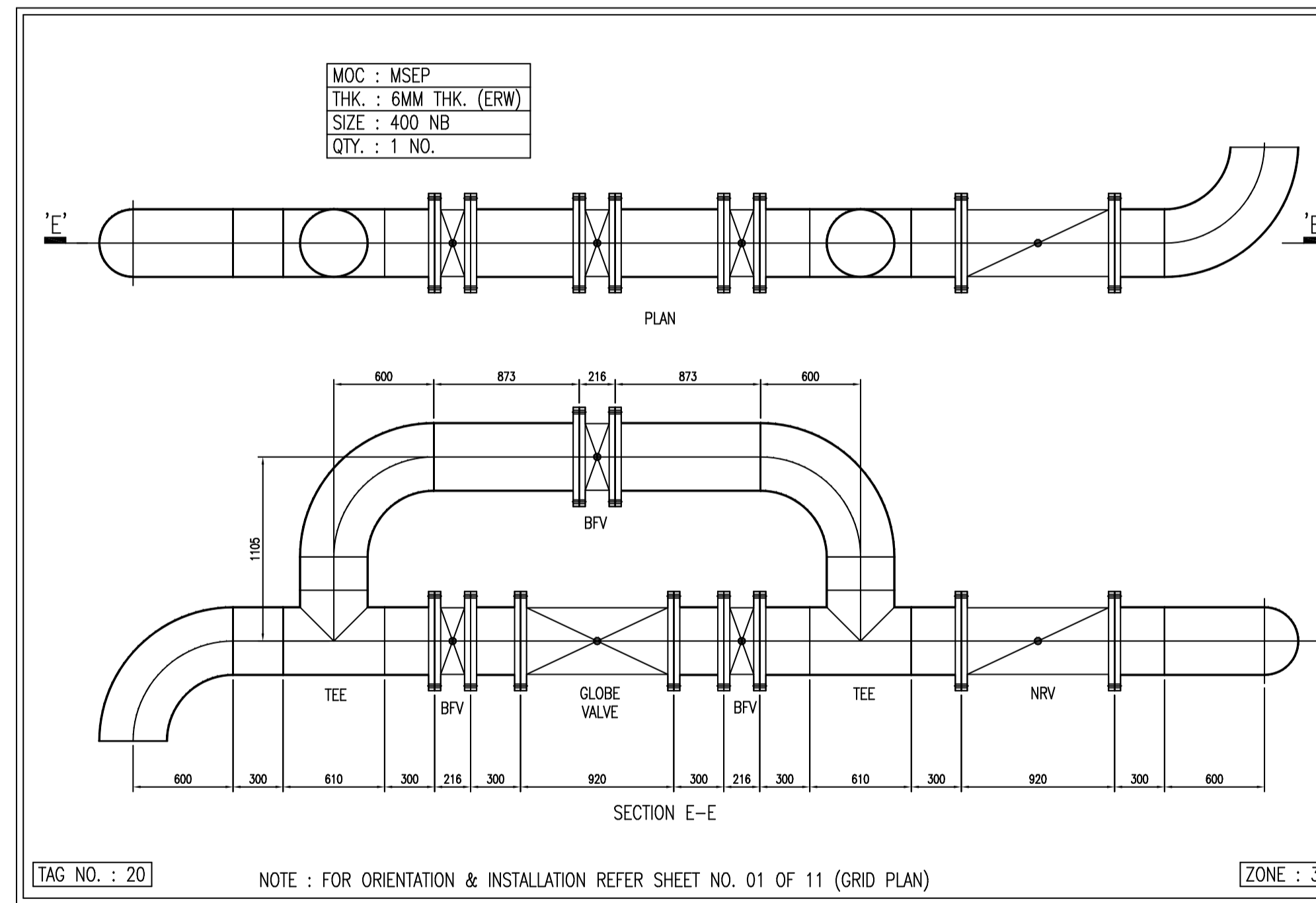
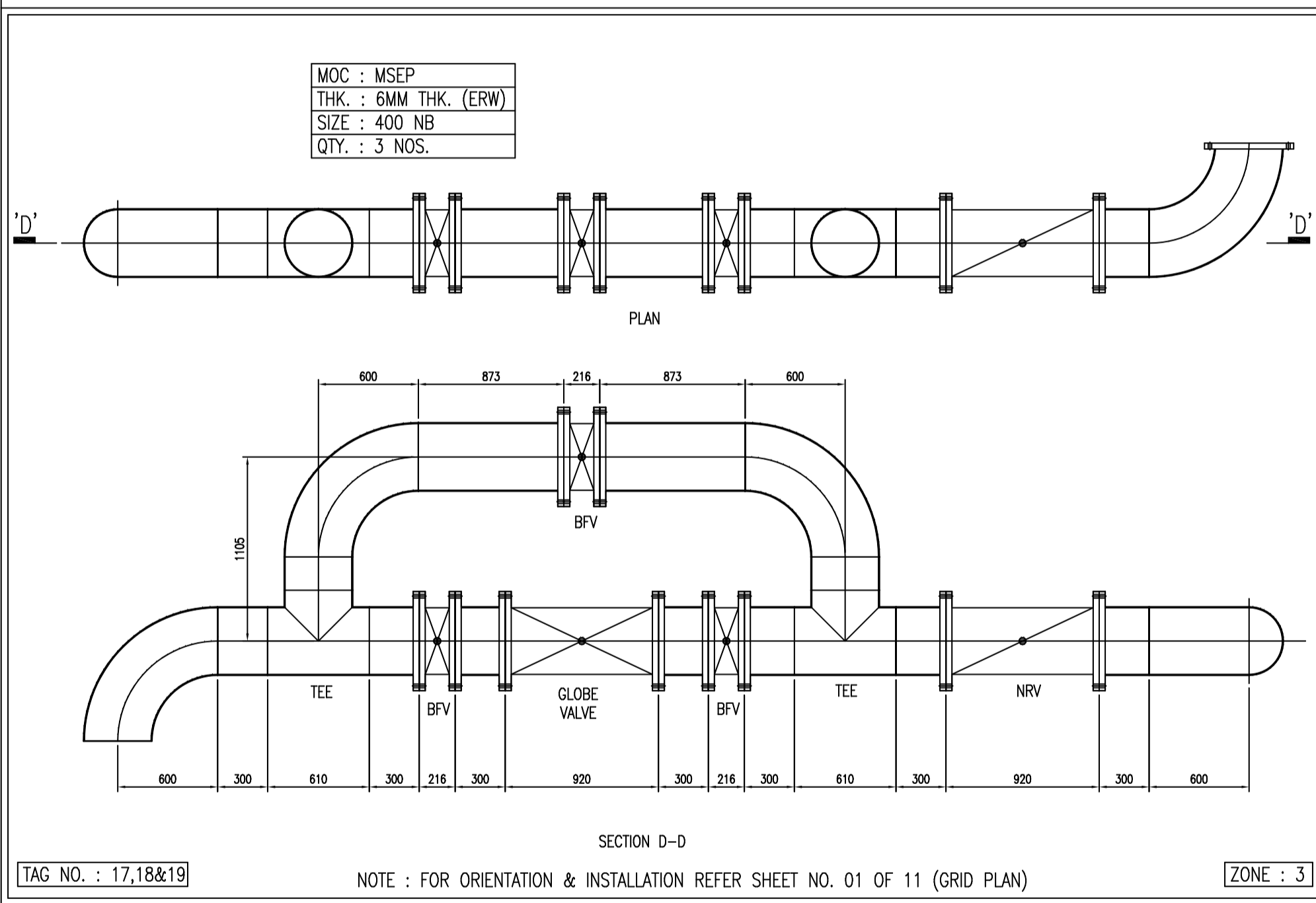
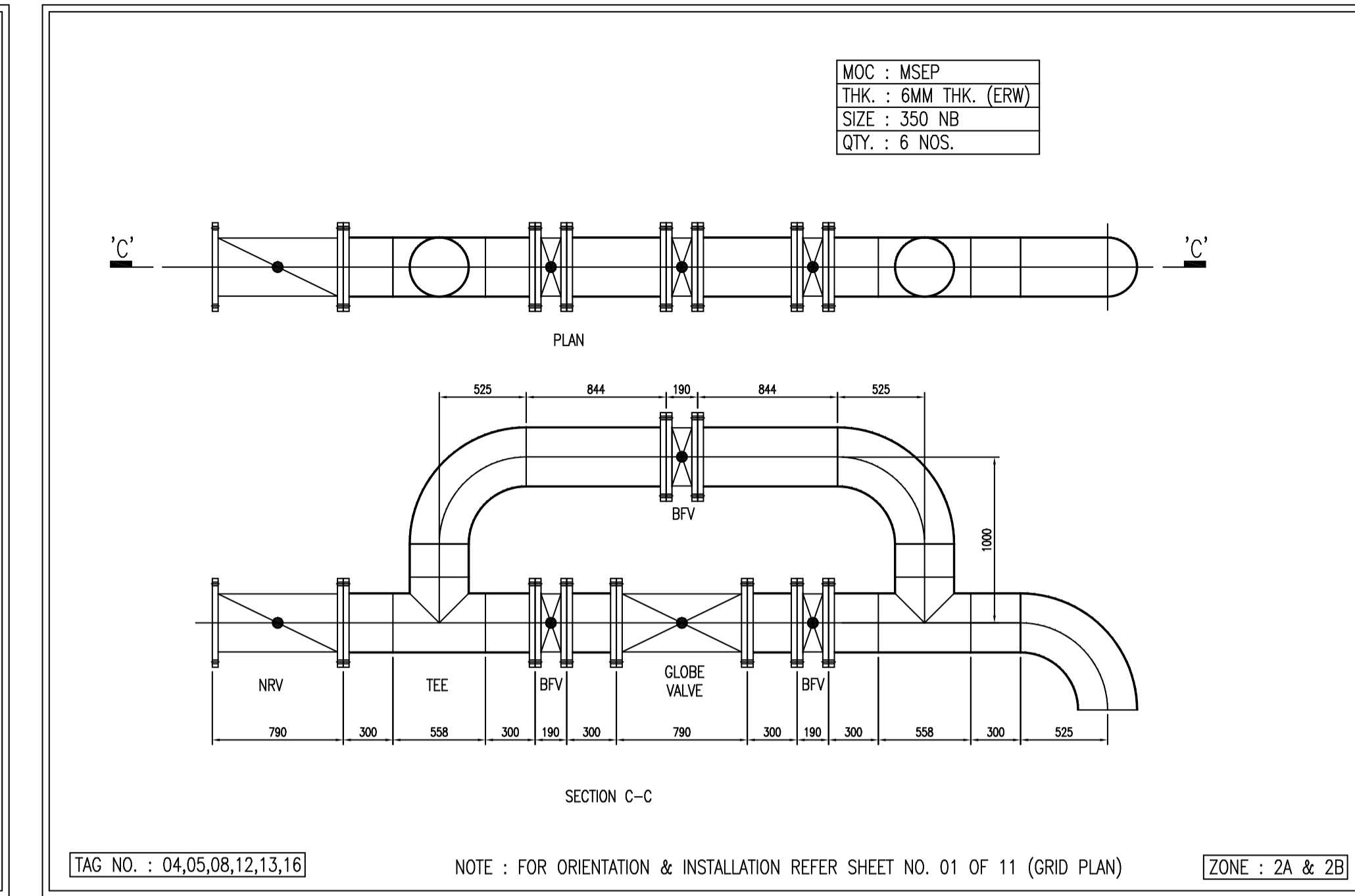
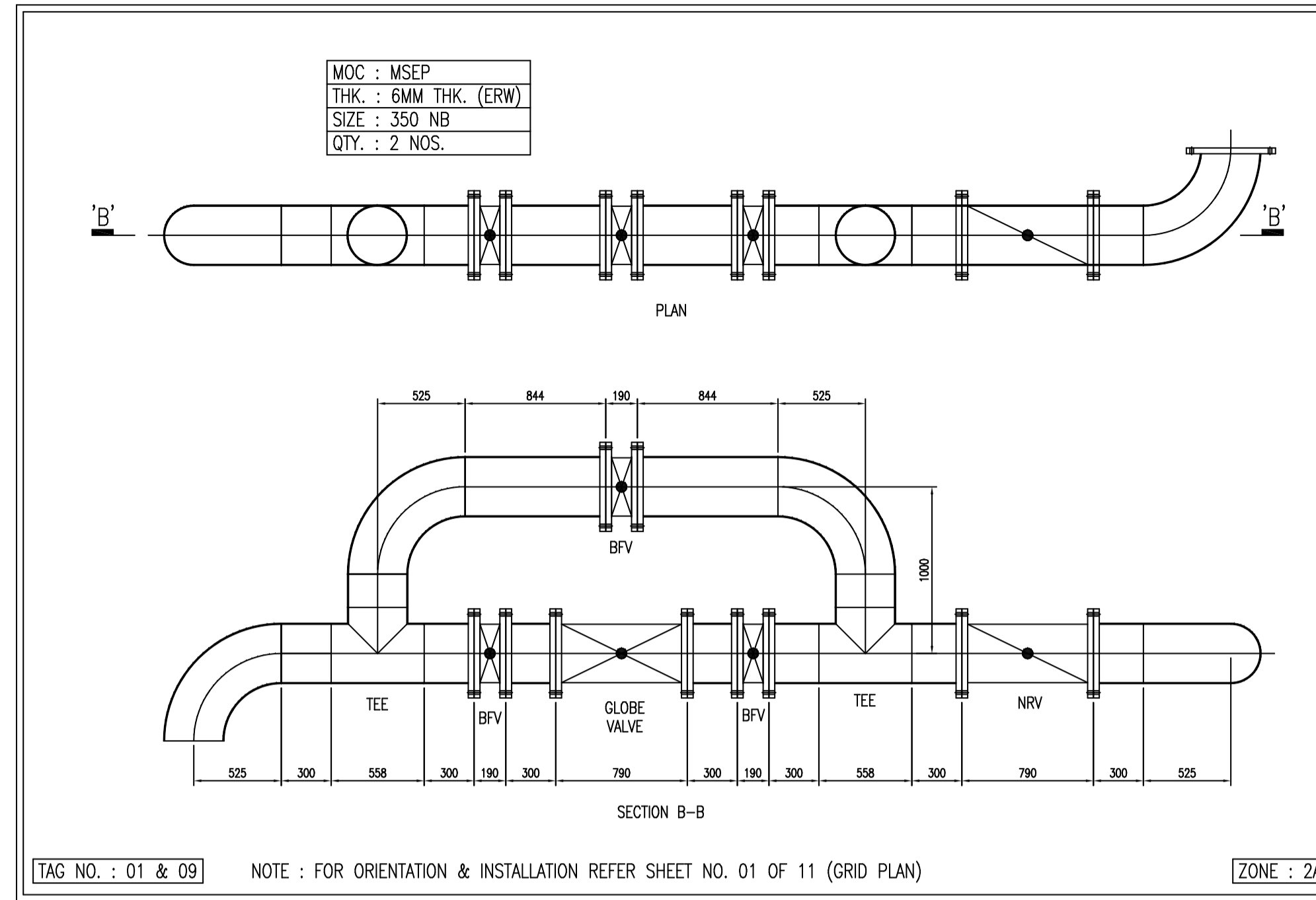
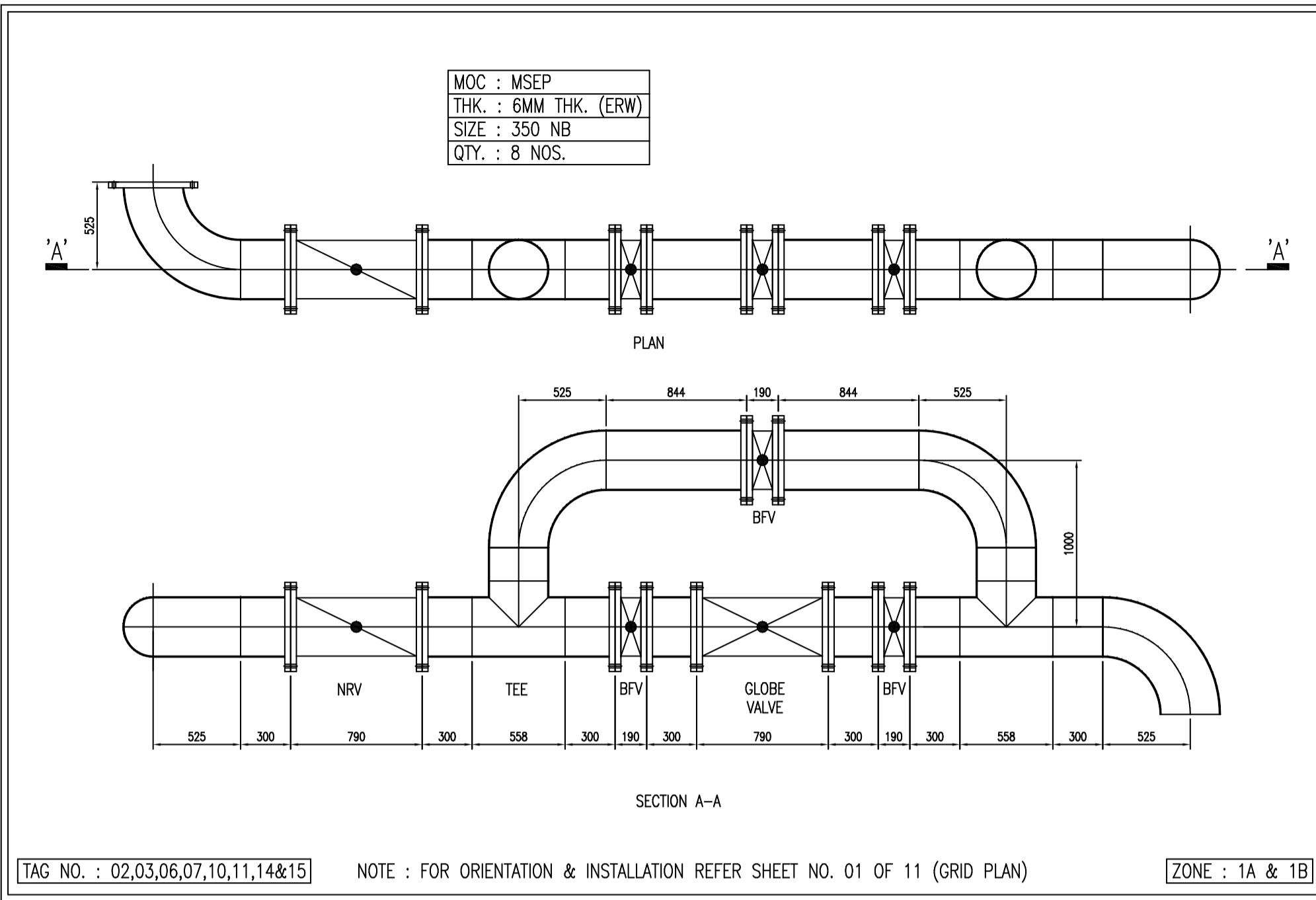

01) ALL FLANGES ARE AS PER "IS 2062 GR B." "ANSI B16.5 150 # SOFF" R2

## AIR INLET ASSEMBLY

READY FOR FABRICATION

NOTES:  
01) ALL DIMENSIONS ARE IN MM AND LEVELS ARE IN METERS

REVISIONS :

NO.	DATE	DESCRIPTION
R0	24-04-2014	---
R1	09-12-2014	READY FOR CONSTRUCTION
R2	30-07-2015	READY FOR CONSTRUCTION (REV. MARKED IN DRAWING) ADDED VALVE DIMENSION

OWNER : NAROL TEXTILE INFRASTRUCTURE & ENVIRO MANAGEMENT

PRINCIPAL EPC AGENCY :  
**ADVENT ENVIRO CARE**  
TECHNOLOGY PVT. LTD.  
(AHMEDABAD)

PROJ NO : -- PROJ TITLE : COMMON EFFLUENT TREATMENT PLANT

DRG NO : -- DRG TITLE : CFICASS AIR GRID (SHEET NO. : 09 OF 11)

DRAWN : VP CHECKED : RS SCALE : -- DATE : 24-04-14

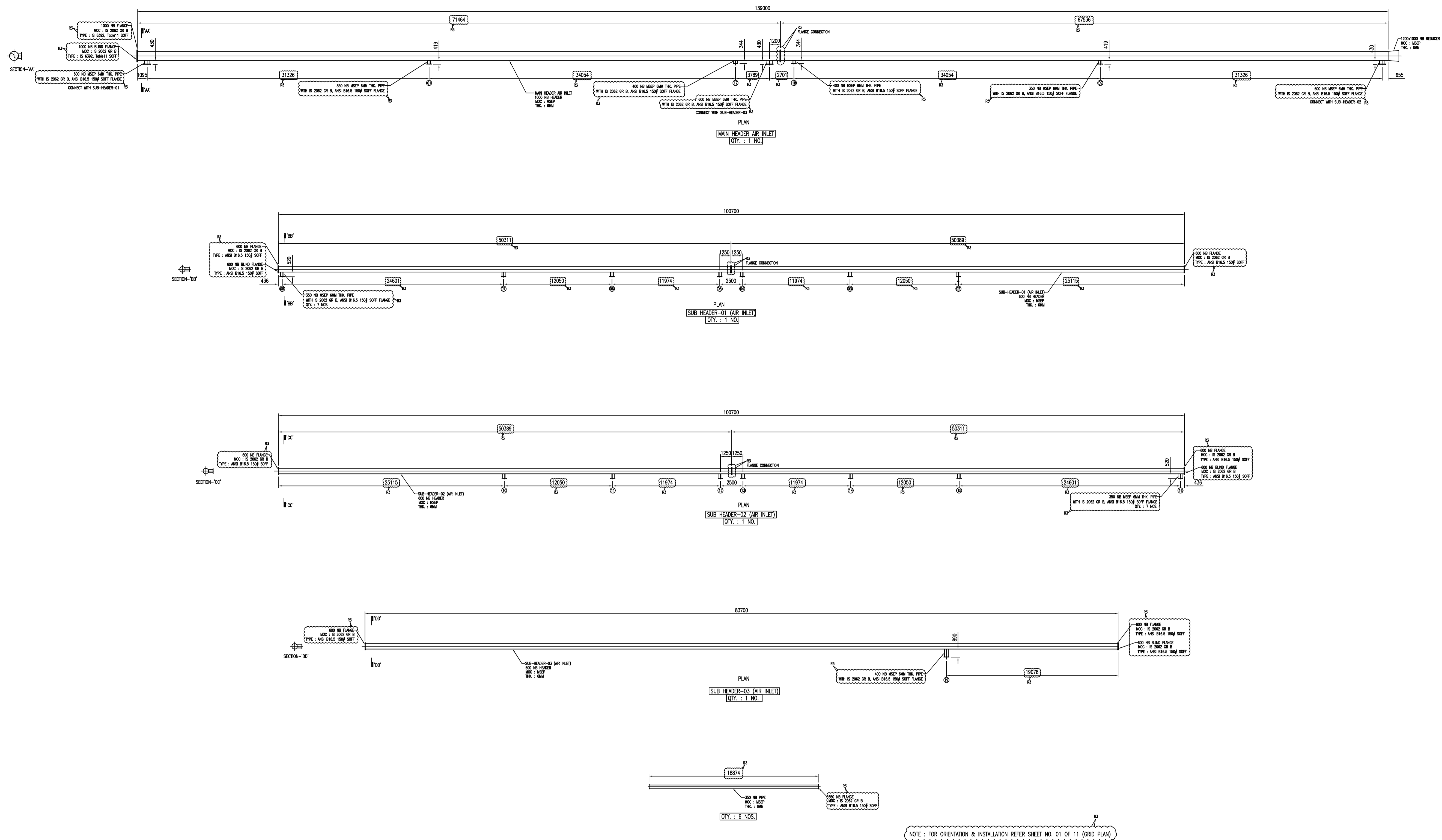

### CFICASS AIR INLET HEADERS

READY FOR FABRICATION

**NOTES:**  
01) ALL DIMENSIONS ARE IN MM AND LEVELS ARE IN METERS

**REVISIONS :**

NO.	DATE	DESCRIPTION
R0	24-04-2014	---
R1	09-12-2014	READY FOR CONSTRUCTION
R2	18-02-2015	REVISION MARKED IN DRAWING
R3	30-07-2015	REVISION MARKED IN DRG. (FLANGE CONN. ADDED) (HEADER CONNECTION LOCATION REVISED)

OWNER: **NAROL TEXTILE INFRASTRUCTURE & ENVIRO MANAGEMENT**

PRINCIPAL EPC AGENCY :  
  
**ADVENT ENVIRO CARE**  
 TECHNOLOGY PVT. LTD.  
 (AHMEDABAD)

PROJ NO : ---  
 PROJ TITLE : **COMMON EFFLUENT TREATMENT PLANT**

DRG NO : ---  
 DRG TITLE : **CFICASS AIR GRID**  
 (SHEET NO. : 10 OF 11)

DRAWN : VP	CHECKED : RS	SCALE : ---	DATE : 24-04-14
------------	--------------	-------------	-----------------

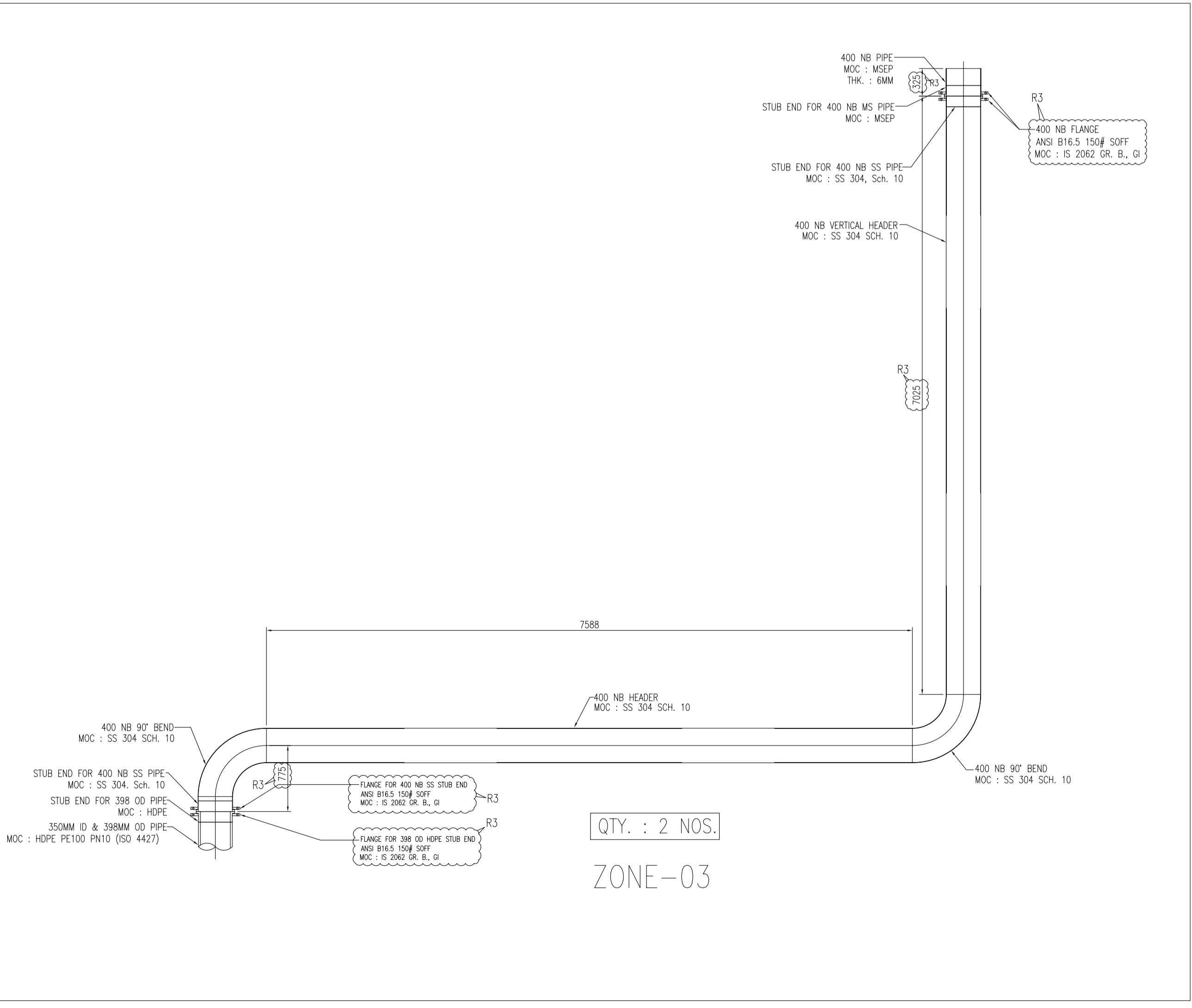
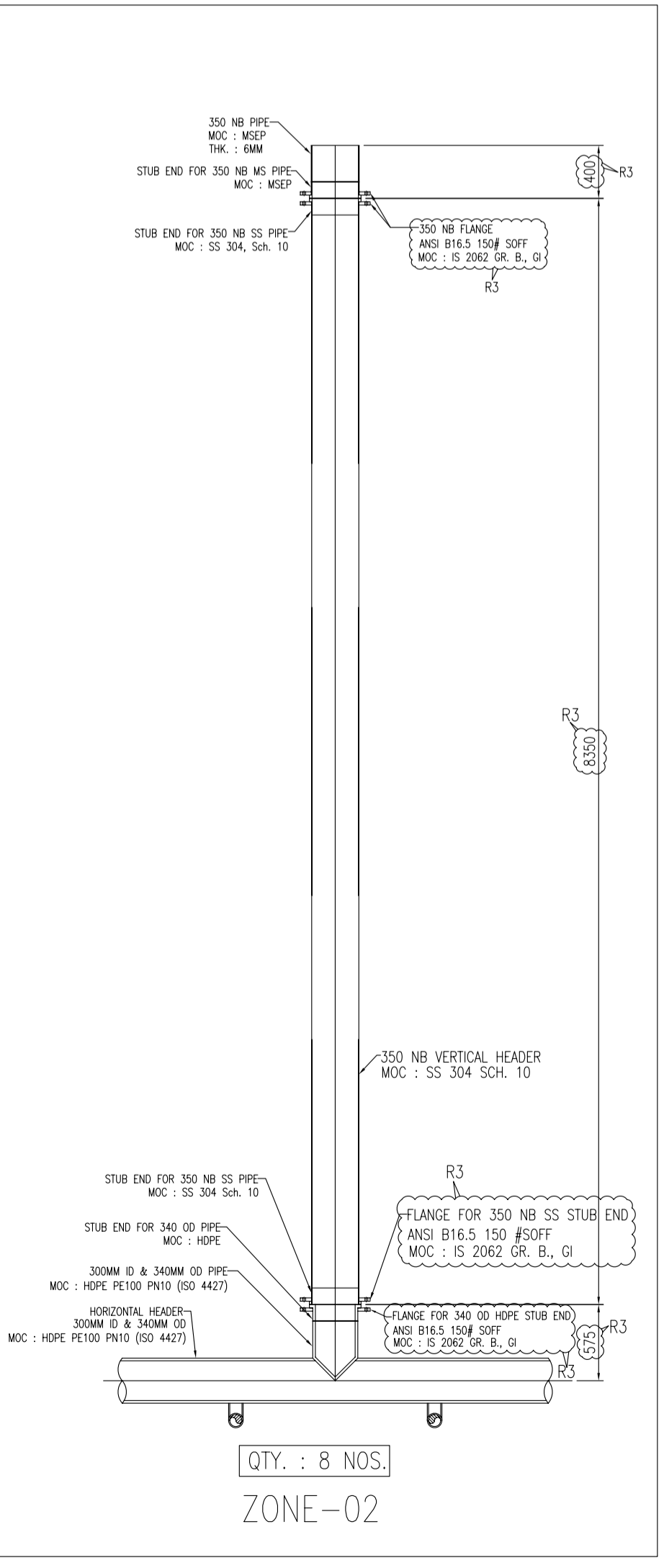
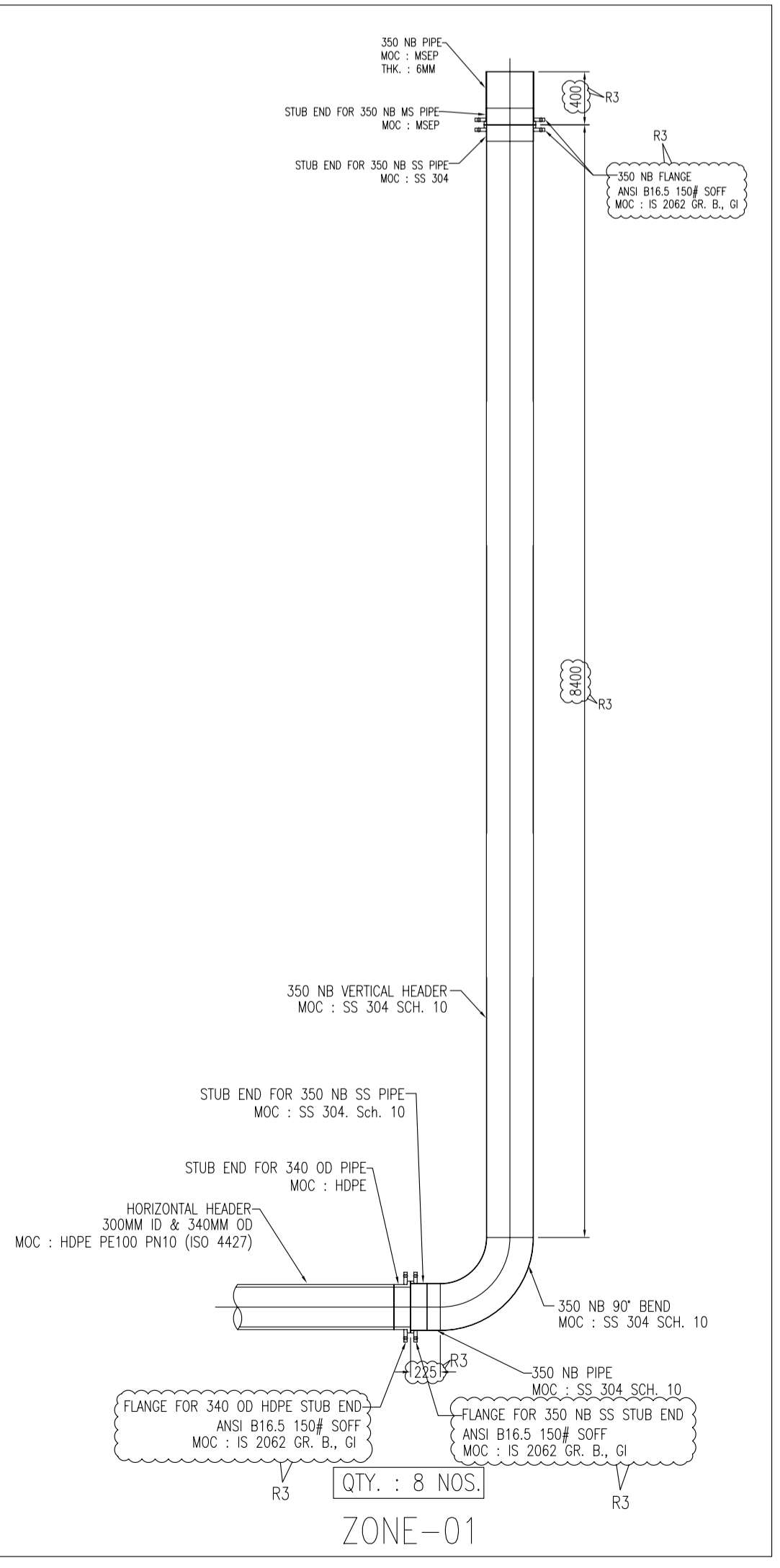
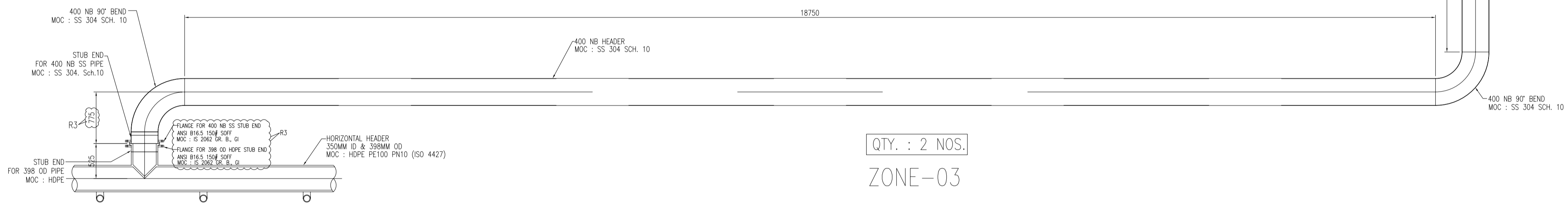

**CFICASS VERTICAL AIR HEADER FOR AIR GRID**

READY FOR FABRICATION

**NOTES:**  
01) ALL DIMENSIONS ARE IN MM AND LEVELS ARE IN METERS

**REVISIONS :**

NO.	DATE	DESCRIPTION
R0	24-04-2014	---
R1	09-12-2014	READY FOR CONSTRUCTION
R2	18-02-2015	REVISION MARKED IN DRAWING
R3	30-07-2015	REVISION MARKED IN DRAWING

OWNER : **NAROL TEXTILE INFRASTRUCTURE & ENVIRO MANAGEMENT**

PRINCIPAL EPC AGENCY : **ADVENT ENVIRO CARE TECHNOLOGY PVT. LTD. (AHMEDABAD)**

PROJ NO : --	PROJ TITLE : <b>COMMON EFFLUENT TREATMENT PLANT</b>
DRG NO : --	DRG TITLE : <b>CFICASS AIR GRID (SHEET NO. : 11 OF 11)</b>
DRAWN : VP	CHECKED : RS
SCALE : --	DATE : 24-04-14